

CROWN

RT 4000 SERIES

Specifications
Rider Pallet Truck

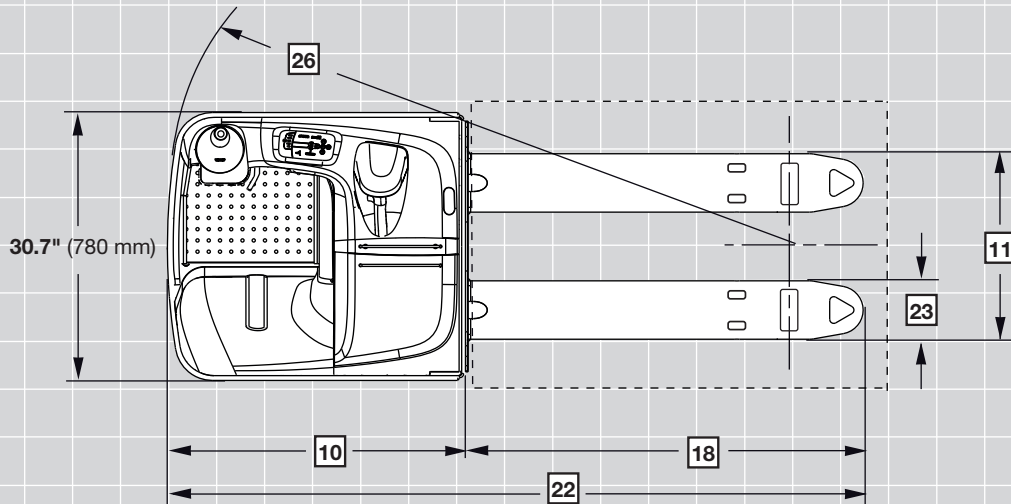

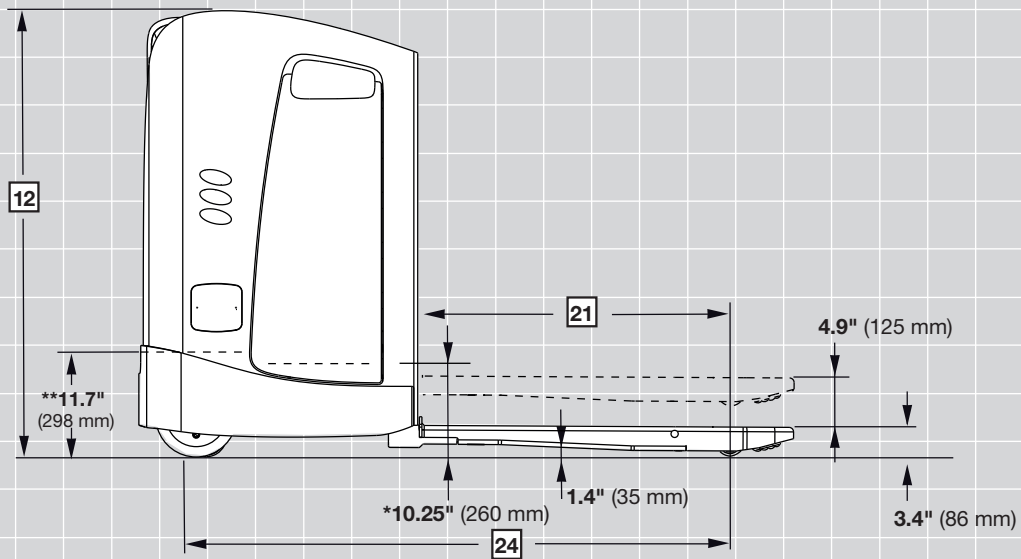

* 10.25" (260 mm) Battery Rollers
 ** Operator Stand Height

Standard-Tip Fork (48" Length)

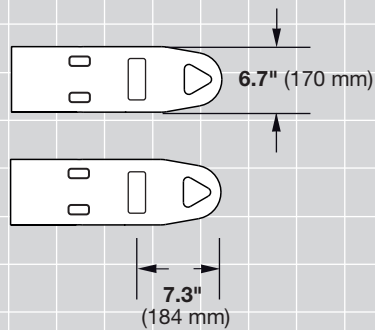

Extended-Tip Fork (96" Length)

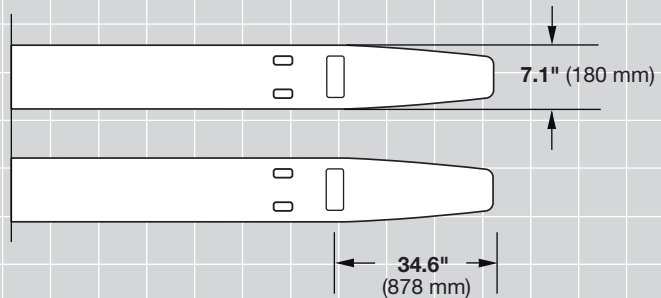

RT 4000 Series

Specifications

			Imperial	Metric	
General Info	1	Manufacturer	Crown Equipment Corporation		
	2	Model	RT 4020		
	3	Load Capacity	lb kg	4500 2040	
	4	Operator Type	Stand-up		
	5	Power	V/ah	24V / 620 Max	
Dimensions	6	Max Battery Size (WxLxH)	*Option 1 in mm	8.8x25.43x32.5	224x646x825
			Option 2	8.8x25.43x27.5	224x646x700
			*Option 3	11.1x25.43x32.5	282x646x825
			Option 4	11.1x25.43x27.5	282x646x700
	7	Battery Weight	Min / Max lb kg	540/1100	245/500
	8	Lift Height	in mm	8.3	211
	9	Lift	in mm	4.9	125
	10	Head Length	in mm	34.5	876
	11	Outside Fork Spread	Standard Tip in mm	21.3/22/26.4	540/560/670
			Extended Tip in mm	21.6/22.4/26.8	550/570/680
12	Steering Wheel Height	in mm	51.3	1302	
13	Speed Travel	w/wo Load mph kmh	5.6/7.8	9.0/12.5	
Wheels and Tires	14	Drive Tire	in mm	9.8x3	250x75
	15	Load Wheels	in mm	3.2x3.9	82x100
	16	Caster Wheels	in mm	4.9x2.4	125x60

* Not available with Onboard Charger

Forks	Model RT 4000		Standard-Tip Forks		Extended-Tip Forks	
			Imperial	Metric	Imperial	Metric
	17	Nominal Fork Length	in mm	48	1220	96
18	Actual Fork Length	in mm	47.2	1200	95.7	2430
19	Fork Tip Length	in mm	7.2	184	34.6	878
21	Load wheel distance	Raised * in mm	37.7	957	58.8	1493
22	Overall Length	in mm	81.7	2076	130.2	3306
23	Fork width	in mm	6.7	170	7.1	180
24	Wheelbase	Raised * in mm	65.2	1656	86.3	2192
25	Grade clearance	%	12		12	
26	Turning radius	Raised * in mm	72.2	1833	93.3	2369
27	Truck weight	w/wo Max Battery lb kg	2632/1530	1194/694	2822/1720	1280/780

* Forks lowered +2.3" (58 mm)

Standard Equipment

1. Crown Manufactured AC traction motor
2. e-Gen® Braking System offers regenerative and frictionless electric braking (mechanical braking applies only as parking brake)
3. Crown Access 1 2 3® Comprehensive System Control
 - LCD display
 - Keyless start up with PIN code
 - Start up and run time diagnostics
 - Battery discharge indicator and lift interrupt
 - 3 selectable traction performance profiles
 - Hour meters for monitoring various truck operating components
 - Onboard diagnostics with real time trouble-shooting capabilities
 - Steering wheel direction indicator
4. Operator compartment – RT 4020
 - Suspended floorboard
 - Integrated presence sensor
 - Wraparound soft foam lean pad
5. Sealed electrical Deutsch Connectors
6. Electric power disconnect switch
7. Vulkollan drive tire, caster wheels and load wheels
8. Single load wheels
9. Ramp hold
10. Battery connector SB 175 gray
11. Heavy-duty reinforced fork assembly
12. Heavy-duty chassis with heavy-gauge steel skirt
13. Easily removable steel covers
14. Steel battery cover for easy battery access
15. Intelligent Electronic Steering System with speed reduction in curves
16. Pallet entry rollers
17. Battery rollout

Optional Equipment

1. Fork length and spread options
2. Battery connector SB 175 red, SB 350 gray, SB 350 red
3. Onboard charger (max battery height 27.5" (700 mm))
4. Traction tire options: Rubber, rubber siped, Supertrac, or Powerfriction
5. Freezer conditioning
6. InfoLink® ready
7. 12V clean power supply
8. Key switch or key pad
9. Load backrest
10. Audible travel alarm
11. Special paint
12. Strobe light
13. Work Assist® accessory tube
 - Storage pockets
 - Beverage holder
 - Scan gun holder
 - Small, medium and large clip boards

Electrical

24 volt electrical system managed by Crown's Access 1 2 3 Comprehensive System Control. Virtually maintenance-free AC traction motor provides strong acceleration and control at any speed.

Power Unit

Designed to take the abuse of dock work, the rugged power unit features a reinforced steel skirt to protect drive unit, caster components, battery and lift linkage. Removable steel covers ensure internal components are protected against impacts yet easily accessible for service.

Operator Area and Controls

The RT 4020 features a patented Entry Bar Safety Switch which alerts operators if their foot is outside the protection of the operator compartment. If the operator steps on the Entry Bar, traction is disengaged, an alarm sounds and "Entry Bar" is shown on the truck display. Low step height and wide, rounded access make it easy to step on and off the truck. A contoured lean pad on the RT 4020 provides a soft contact surface to lean against. Side-stance operation provides for excellent visibility in both driving directions. The hand grip is urethane covered for insulation from cold and vibration with integrated horn button for easy activation. An ergonomic forward/reverse thumb wheel allows for precise maneuvering. The electronic steering improves maneuverability and responsiveness, even with heavy loads. Combined with speed control in curves, electronic steering safely delivers top driving performance.

Access 1 2 3® Comprehensive System Control

Crown's Access 1 2 3 technology provides optimum performance and control by offering a communications interface for the operator and service technician, intelligent coordination of lift truck systems and simplified service with advanced diagnostics. The display includes a full featured on-board service tool so service technicians can actively view inputs and outputs during truck operation. No laptop or service terminal is required. Event code history, including the last 16 events, is accessible through the display. The display provides a convenient interface for operators, keeping them informed (hour meters, BDI, operator messages, service codes) of any changes impacting truck performance and allowing them to

choose from three performance profiles when enabled. Performance tuning can be accessed at the display to customize truck performance for specific applications or operator requirements. In addition, up to 25 PIN codes can be assigned to individual operators and matched to one of the pre-programmed performance profiles if desired.

e-GEN® Braking System

The power of the high-torque AC traction motor is used to stop the truck and keep it static until a travel input is requested, even when operating on a gradient. This system eliminates adjustments and wear points for a lifetime of maintenance free use. An automatic parking brake activates if the truck is stopped and the operator leaves the platform or power is disconnected.

Other Options

1. Audible travel alarm
 2. Flashing lights
- Safety considerations and dangers associated with audible travel alarms and flashing lights include:
- Multiple alarms and/or lights can cause confusion.
 - Workers ignore the alarms and/or lights after day-in and day-out exposure.
 - Operator may transfer the responsibility for "looking out" to the pedestrians.
 - Annoys operators and pedestrians.

Dimensions and performance data given may vary due to manufacturing tolerances. Performance is based on an average size vehicle and is affected by weight, condition of truck, how it is equipped and the conditions of the operating area. Crown products and specifications are subject to change without notice.



Crown Equipment Corporation
New Bremen, Ohio 45869 USA
Tel 419-629-2311
Fax 419-629-3796
crown.com

You can count on Crown to build lift trucks designed for safe operation, but that's only part of the safety equation. Crown encourages safe operating practices through ongoing operator training, safety-focused supervision, maintenance and a safe working environment. Go to crown.com and view our safety section to learn more.

Because Crown is continually improving its products, specifications are subject to change without notice.

Crown, the Crown logo, the color beige, the Momentum symbol, Access 1 2 3, e-GEN, InfoLink, QuickPick, and Work Assist are trademarks of Crown Equipment Corporation.

Copyright 2006-2017 Crown Equipment Corporation
SF19509 01-17
Printed in U.S.A.