

**CROWN**

# SHR 5500 SERIES

## Specifications

Heavy-Duty Walkie  
Reach Stacker



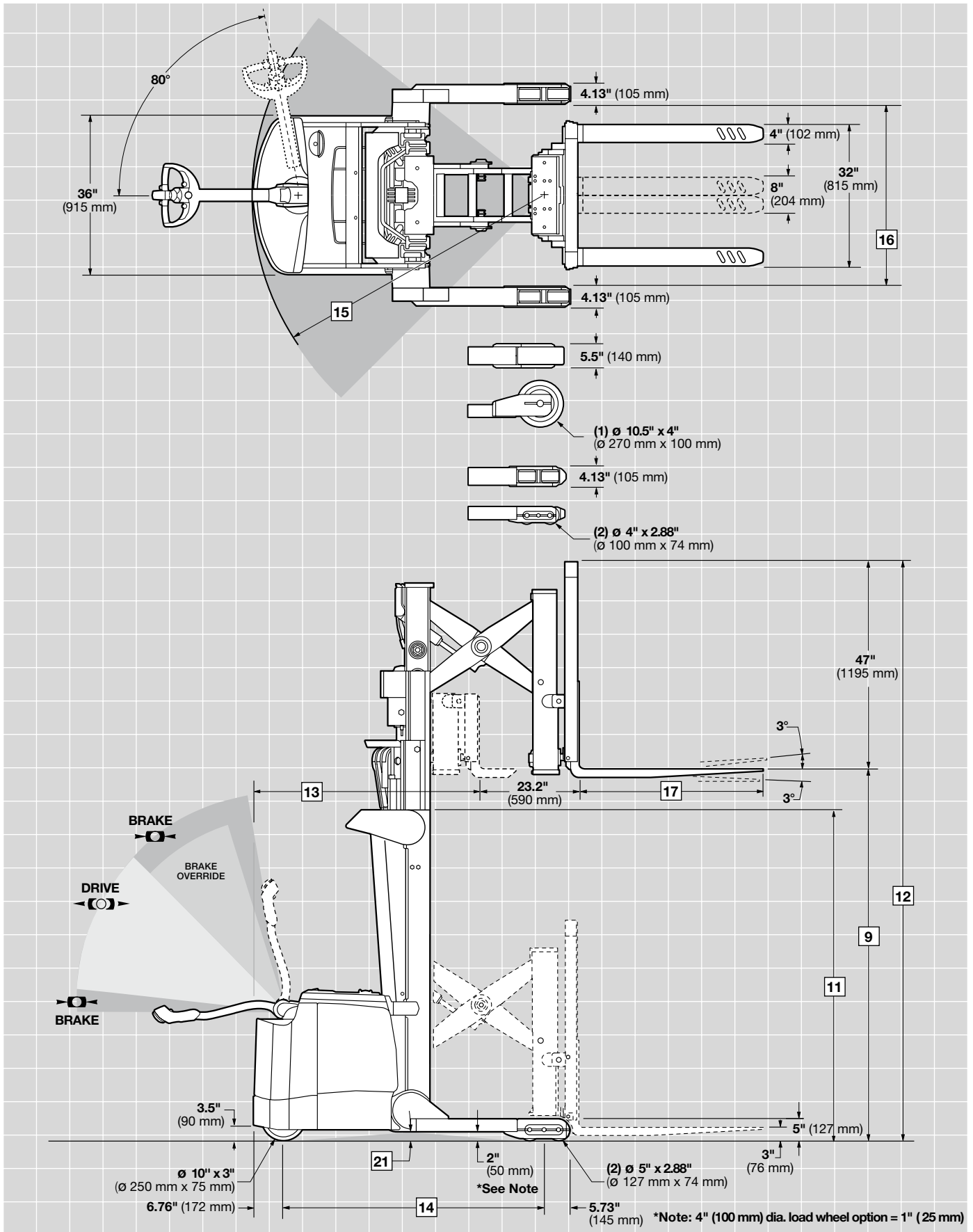

# SHR 5500 Series

# Specifications

				Imperial	Metric	Imperial	Metric	
General Information	1	Manufacturer		Crown Equipment Corporation				
	2	Model		SHR 5520-25 and SHR 5520-30		SHR 5540-35		
	3	Load Capacity	lb kg	See Chart				
	4	Load Center	in mm	24	600	24	600	
	5	Power	Electric	24 Volts				
	6	Operator Type	Walkie	Reach Stacker				
	7	Tire Type	Load / Drive	Poly / Vulkollan				
	8	Wheels (x = driven)	Load / Drive	4 / 1x				
Dimensions	9	Lift Height	in mm	See Chart				
	13	Head Length*	in mm	44	1120	50.5	1285	
	14	Wheelbase	in mm	52.7	1340	59.2	1505	
	15	Turning Radius	in mm	59.4	1510	65.9	1675	
	16	Inside Straddle	in mm	34 - 50" in 2" increments	865 - 1270 mm in 50 mm increments	34 - 50" in 2" increments	865 - 1270 mm in 50 mm increments	
	17	Forks	Standard L x W x T Optional Lengths	in mm	36 x 4 x 1.75 30, 39, 42, 45, 48, 54, 60	915 x 102 x 44 760, 990, 1060, 1145, 1220, 1370, 1525	36 x 4 x 1.75 30, 39, 42, 45, 48, 54, 60	915 x 102 x 44 760, 990, 1060, 1145, 1220, 1370, 1525
Performance	18	Travel Speeds	Empty / Loaded mph km/h	3.7 / 3.4	5.9 / 5.4	3.7 / 3.4	5.9 / 5.4	
	19	Lift Speeds	Empty / Loaded fpm m/s	48.4 / 29.5	.245 / .145	48.4 / 29.5	.245 / .145	
	20	Lowering Speeds	Empty / Loaded fpm m/s	50 / 50	.250 / .250	50 / 50	.250 / .250	
	21	Grade Clearance**	** 4" / 5" & 10.5" (100 / 130 mm & 265 mm)	%	9 / 17	9 / 17	8 / 15	8 / 15
	22	Battery	Min Weight / Max Amp	lb kg	510 / 300	230 / 290	975 / 660	445 / 585
			Max Battery Size W x L x H	in mm	6.62 x 34.37 x 24.8	168 x 873 x 630	13.12 x 31.10 x 24.8	333 x 790 x 630
		Cable Lead Length / Connector Position	in mm	20 / B	510 / B	20 / B	510 / B	

\* Add 2.1" (55 mm) for Sideshift

\*\* Load Wheel Size

Mast Type		TL - Limited Free Lift				TT - Triple Telescopic					
		Imperial	Metric	Imperial	Metric	Imperial	Metric	Imperial	Metric		
9	Lift Height	in mm	127.5	3235	150.5	3820	156	3960	192	4875	
3	Load Capacity	SHR 5520-25	lb kg	2500	1130	2500	1130	2500	1130	na	na
		SHR 5520-30	lb kg	3000	1360	3000	1360	3000	1360	na	na
		SHR 5540-35	lb kg	3500	1585	3500*	1585*	3500	1585	3500**	1585**
10	Free Lift	with LBR	in mm	6	150	6	150	28	710	42	1065
11	Collapsed Height		in mm	83.5	2120	95.5	2425	75	1905	89	2260
12	Extended Height	with LBR	in mm	175	4445	198	5030	204	5185	240	6100
23	Min ID Straddle Width		in mm	34	865	34	865	34	865	42	1065
24	Truck Weight without Battery***	SHR 5520-25	lb kg	3585	1625	3690	1675	4130	1875	na	na
		SHR 5520-30	lb kg	4100	1860	4205	1910	4650	2110	na	na
		SHR 5540-35	lb kg	4055	1840	4160	1885	4600	2085	4735	2150

\* Up to 127" (3225 mm), 3350 lb (1550 kg) at 150.5" (3820 mm)

\*\* Up to 156" (3960 mm), 2500 lb (1130 kg) at 192" (4875 mm)

\*\*\* Add 105 lb (55 kg) for Sideshift

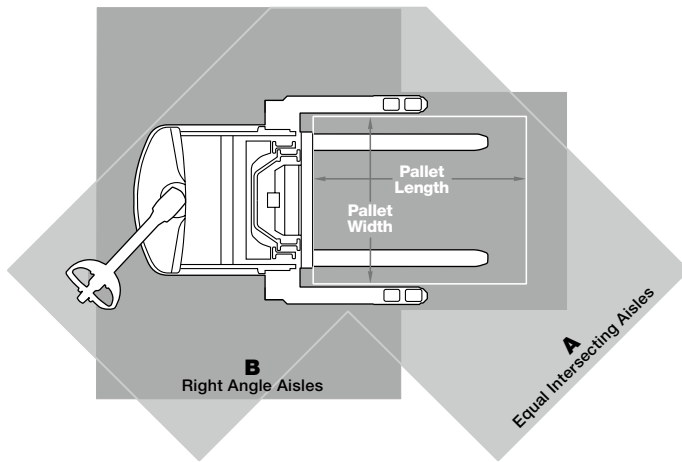

**SHR 5520**

Pallet Width		Pallet Length in (mm)									
		30 (762)		36 (915)		40 (1016)		42 (1067)		48 (1220)	
		A	B	A	B	A	B	A	B	A	B
<b>36</b> 915	in mm	62	78	62	81	62	87	62	89	63	96
		1575	1980	1575	2060	1575	2210	1575	2260	1600	2450
<b>40</b> 1016	in mm	65	78	65	81	65	87	65	90	65	97
		1650	1980	1650	2060	1650	2210	1650	2285	1650	2465
<b>42</b> 1067	in mm	66	78	66	81	66	87	66	90	66	97
		1680	1980	1680	2060	1680	2210	1680	2285	1680	2465
<b>48</b> 1220	in mm	69	79	69	81	69	88	69	91	70	98
		1750	2005	1750	2060	1750	2235	1750	2310	1780	2490

**SHR 5540**

Pallet Width		Pallet Length in (mm)									
		30 (762)		36 (915)		40 (1016)		42 (1067)		48 (1220)	
		A	B	A	B	A	B	A	B	A	B
<b>36</b> 915	in mm	66	83	66	86	66	92	66	94	66	102
		1675	2110	1675	2185	1675	2340	1675	2390	1675	2590
<b>40</b> 1016	in mm	68	83	68	86	68	92	68	95	68	102
		1730	2110	1730	2185	1730	2340	1730	2415	1730	2590
<b>42</b> 1067	in mm	69	84	69	87	69	93	69	95	69	103
		1755	2135	1755	2210	1755	2365	1755	2415	1755	2615
<b>48</b> 1220	in mm	72	84	72	87	72	93	72	96	73	104
		1830	2135	1830	2210	1830	2365	1830	2450	1855	2640

A = Equal Intersecting Aisles  
B = Right Angle Aisles

Add 2.5" (65 mm) if sideshift option is used.  
Add 6" (150 mm) to 12" (300 mm) to all aisle dimensions for maximum maneuverability.

**Capacity**

Model SHR 5520-25:  
2500 lb (1130 kg) at  
24" (600 mm) load center

Model SHR 5520-30:  
3000 lb (1360 kg) at  
24" (600 mm) load center

Model SHR 5540-35:  
3500 lb (1585 kg) at  
24" (600 mm) load center

**Maximum Battery Size**

SHR 5520-25 and SHR 5520-30:  
6.62" wide x 34.37" long x 24.8" high (168 x 873 x 630 mm)  
– up to 300 amp hours, 24 volts

SHR 5540-35:  
13.12" wide x 31.10" long x 24.8" high (333 x 790 x 630 mm)  
– up to 660 amp hours, 24 volts

**Standard Equipment**

- 24-volt electrical system
- Crown's Access 1 2 3<sup>®</sup> Comprehensive System Control

- Access 1 2 3 display
  - Eight-character scrolling display, 5 button access
  - Three selectable performance levels
  - BDI with lift interrupt
  - Five hour meters
  - Event codes
  - Access 1 2 3 diagnostics with real time troubleshooting
  - PIN code capability
- AC traction and steer motors
- Performance enhancing features
  - X10<sup>®</sup> Handle (tilt and reach standard)
  - Brake override
  - Electronic power steering
  - Ramp hold and speed control
  - Power boost
  - High-visibility mast and carriage
  - Low profile power unit
  - Tool storage tray
- Wire mesh guard - mast

**SHR 5500 Series**

**Technical Information**

- Vulkollan drive tire – 10" dia. x 3" wide (250 x 75 mm)
- Polyurethane load wheels – 5" dia. x 2.88" wide (127 x 74 mm)
- InfoPoint<sup>®</sup> System
- Steel power unit covers
- 32.8" wide x 47" tall load backrest (835 x 1195 mm)
- Emergency power disconnect
- Key switch
- Horn
- SB175 gray battery connector
- Reversing button
- Electric park brake
- Fork tip indicators
- Battery compartment rollers
- Optional Equipment
  - 30 amp on-board charger (6.62" [168 mm] battery box)
  - Keyless on-off switch
  - Work Assist<sup>®</sup> Accessories:
    - Clip pad
    - Hook
    - Clip pad and hook
    - Pocket
    - Fan
- Sideshift with internal hosing 4" (100 mm) sideshift each direction – reduces capacity 300 lb (140 kg)
- Optional fork lengths (30", 39", 42", 45", 48", 54", 60") (760, 990, 1060, 1145, 1220, 1370, 1525 mm)
- Freezer conditioning (Continuous -30° C / -22° F)
- Plexiglass safety shield
- 10" dia. x 4" wide drive tire (250 x 100 mm)
  - Soft poly
  - Siped soft poly
- Polyurethane load wheels
  - 4" dia. x 2.88" wide (100 x 74 mm)
  - 1" [25 mm] under clearance below outriggers
  - 10.5" dia. x 4" wide (270 x 100 mm)
- InfoLink<sup>®</sup> ready
- SBE 160 battery connector
- EE Rating

### Operator Controls

Crown's robust X10 handle places all control buttons in the optimum position for ease of operation with either hand and to minimize hand and wrist movements. An ergonomic forward/reverse thumb wheel allows for precise maneuvering. The control hand grips are urethane covered for insulation from cold and vibration with integrated horn buttons for easy activation. The handle contains a safety button which reverses the direction of the truck should the button touch the operator.

The physical efforts to hold the handle at a comfortable height was minimized to reduce fatigue.

A rabbit/turtle switch incorporates two levels of programmable travel performance so operators can select the setting that matches their experience level or application requirements.

Exclusive brake override feature allows slow speed travel with the handle near vertical. This feature improves maneuverability in tight areas.

### Performance

The SHR 5500 Series incorporates the latest generation AC drive system enhanced with Access 1 2 3 technology. Crown's Access 1 2 3 technology continuously monitors truck systems and adjusts system parameters to deliver optimum performance and control. The Access Display provides a convenient interface for operators keeping them informed of any changes impacting truck performance and allowing them to choose from three performance profiles when enabled.

Programmable performance settings enable authorized personnel to tune the lift truck to different operator skill levels, or to meet specific application requirements. In addition, up to 25 PIN codes can be assigned to individual operators and matched to one of the pre-programmed performance profiles if desired.

Electronic power steering allows the operator to maneuver heavy loads in tight spaces throughout the day while minimizing fatigue. Smooth travel and lift performance combine with excellent controls provided by the X10 handle to increase productivity.

The SHR 5500 Series features ramp hold and speed control to improve operation on small inclines or ramps. The ramp hold feature uses the motor to prevent truck movement when the brake is released and no travel command is present. The ramp speed control feature insures that actual travel speed matches requested travel speed. If the truck encounters an obstacle, a power boost feature delivers up to 15 percent more power than normally available for a full three seconds to overcome the obstruction.

### Electrical System

A heavy-duty 24-volt fused electrical system utilizes microprocessor controls for maximum energy efficiency, reduced maintenance and infinite speed control capability.

Access control modules for travel, lift and steer are sealed from dirt, dust and moisture for trouble-free operation. All contactors have been eliminated except for the main line contactor. A 175 amp battery connector with disconnect handle is standard.

### Hydraulic System

Heavy-duty hydraulic motor (4.8 kw) is transistor controlled and matched with a gear type pump selected for optimum lift performance and low noise. Single-speed lift with programmable acceleration - deceleration and programmable two-speed lowering enables customization to match operator preference or application requirements.

Cylinder rods are hard-plated chrome with polyurethane seals. Relief valve tuned to capacity protects all components in the hydraulic system. Reservoir incorporates an in-tank 10 micron return filter for removing debris from oil.

### Drive Unit / Brake

Heavy-duty gearbox with helical spur input gear for quiet operation.

Regenerative motor braking is activated under a downhill condition, during plugging or when the directional control is returned to neutral. An electro-magnetic brake, spring applied and electrically released, is mounted on top of the drive motor. The electro-magnetic brake serves as the parking brake and applies when the control handle position moves from the operating zone to brake zone during truck operation.

### Power Steering

Electronic power steering is provided by a heavy-duty AC motor that pivots the drive unit when steer tiller movement is detected.

### Mast

High visibility two and three-stage mast design with angled cross bracing and lift cylinders located behind nested I-beams provides maximum visibility for load positioning and placement. Crown's staging cushions coupled with lowering dampers ensure smooth operation.

Rolled steel outer mast channels and inner I-beams roll on canted, steel, anti-friction roller bearings for minimal current draw and long life. Mast and chain rollers are sealed and lubricated for life. Telescoping mast sections nest to reduce truck length. Heavier mast cross bracing design increases stiffness.

### Reach Mechanism

An exclusive reach mechanism design provides unmatched visibility at all rack levels.

### Serviceability / Durability

The Access display simplifies service for technicians by providing advanced diagnostics without the need for separate handsets. The display allows the technician to view event service codes and truck hours when event occurred, perform system calibrations or functional tests of components, and make necessary adjustments. Crown's InfoPoint System compliments Access 1 2 3 diagnostics by providing a Quick Reference Guide, on-truck component maps and information nuggets to further simplify troubleshooting. All wiring is color coded.

Removable steel power unit doors are hinged for ease of opening providing excellent accessibility to the distribution panel and all other components. Steel covers provide added protection to critical internal components.

Removable steel battery covers and hinged cover allow easy access to the battery. Battery removal can be accomplished from either side. Battery compartment rollers are standard.

The X10 handle incorporates a vacuum die cast process using high-grade aluminum and benefits from structural webbing for maximum strength and durability.

### Other Options

1. Amber strobe light
2. Travel alarm: reverse, forward or both

Safety considerations and dangers associated with audible travel alarms and strobe lights include:

- Multiple alarms and/or lights can cause confusion.
- Workers ignore the alarms and/or lights after day-in and day-out exposure.
- Operator may transfer the responsibility for "looking out" to the pedestrians.
- Annoys operators and pedestrians.

*Dimensions and performance data given may vary due to manufacturing tolerances. Performance is based on an average size vehicle and is affected by weight, condition of truck, how it is equipped and the conditions of the operating area. Crown products and specifications are subject to change without notice.*



**Crown Equipment Corporation**

New Bremen, Ohio 45869 USA

**Tel** 419-629-2311

**Fax** 419-629-3796

[crown.com](http://crown.com)

**You can count on Crown to build lift trucks designed for safe operation, but that's only part of the safety equation. Crown encourages safe operating practices through ongoing operator training, safety-focused supervision, maintenance and a safe working environment. Go to [crown.com](http://crown.com) and view our safety section to learn more.**

Because Crown is continually improving its products, specifications are subject to change without notice.

Crown, the Crown logo, the color beige, the Momentum symbol, Access 1 2 3, InfoPoint, InfoLink and X10 Handle are trademarks of Crown Equipment Corporation.

Copyright 2008-2016 Crown Equipment Corporation  
SF14906 Rev. 04-16  
Printed in U.S.A.