

CROWN

Spezifikations

TS Series

Turret Sideloader

TS Series

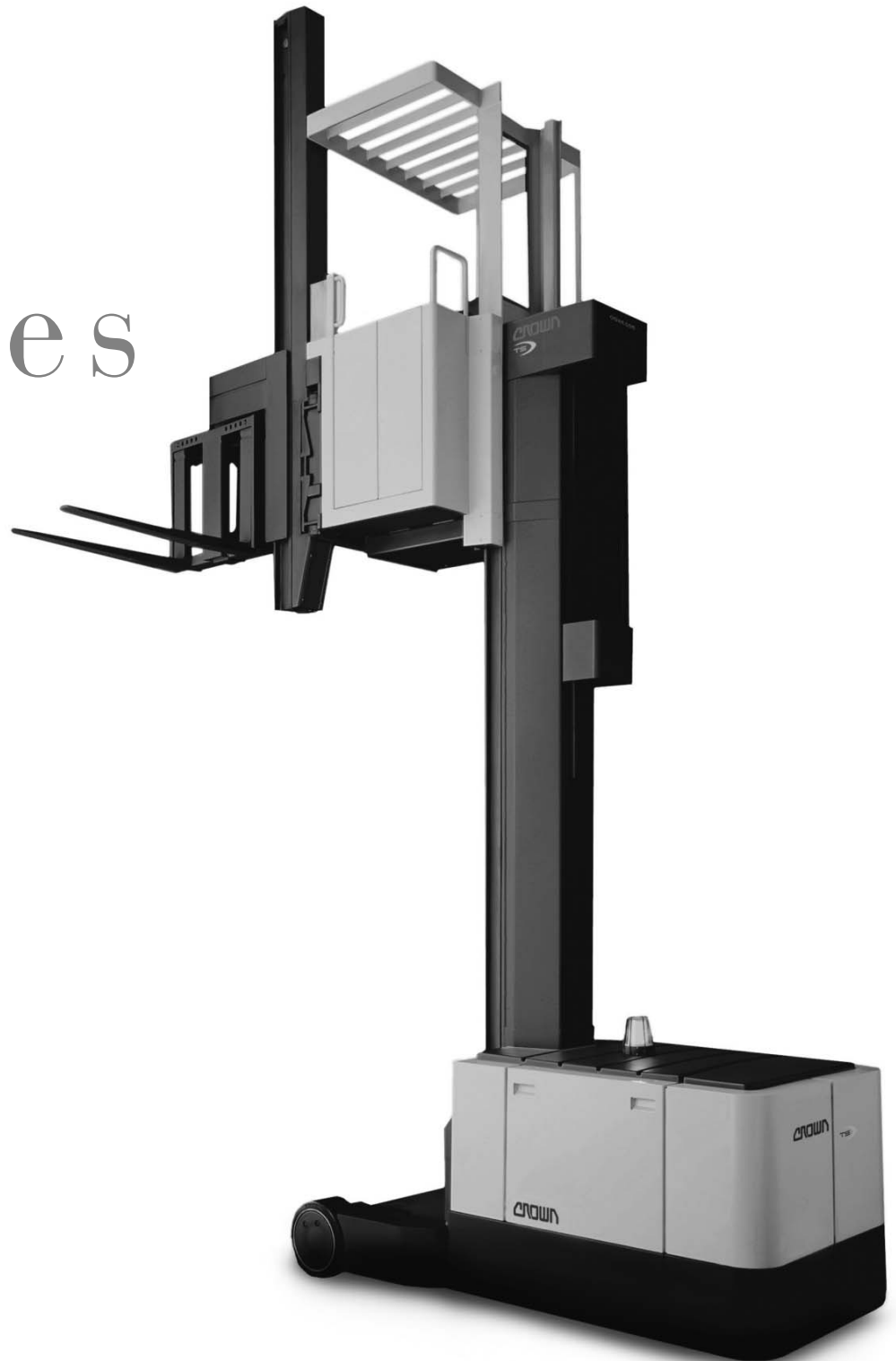

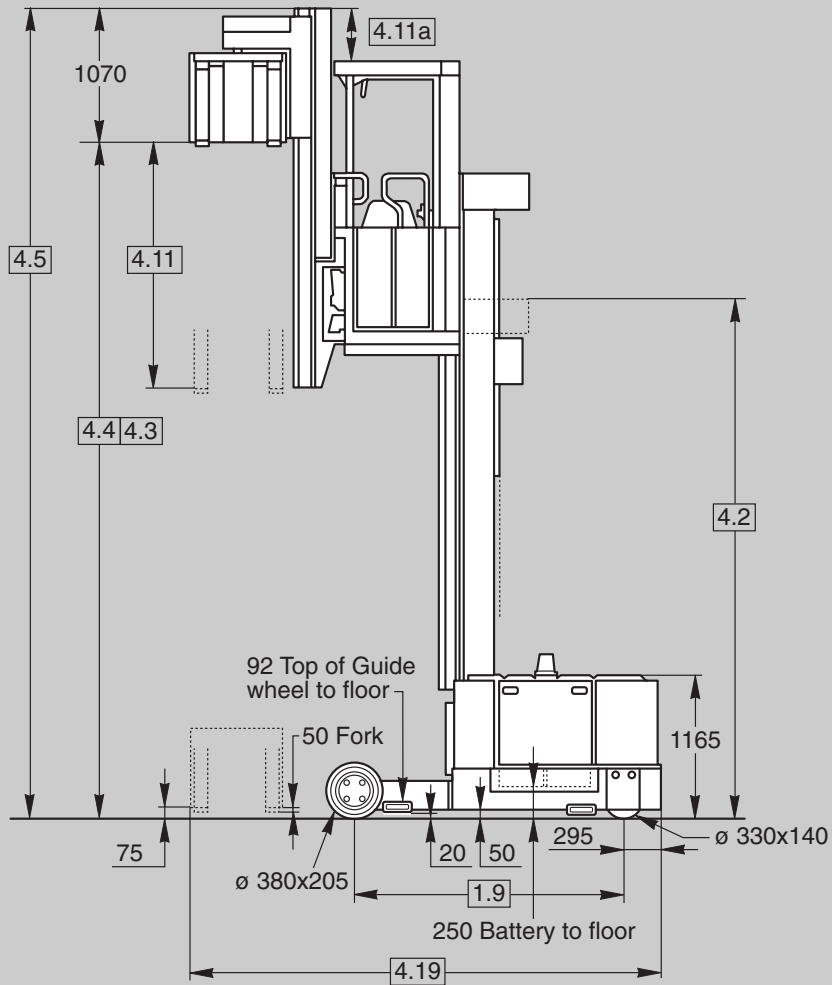
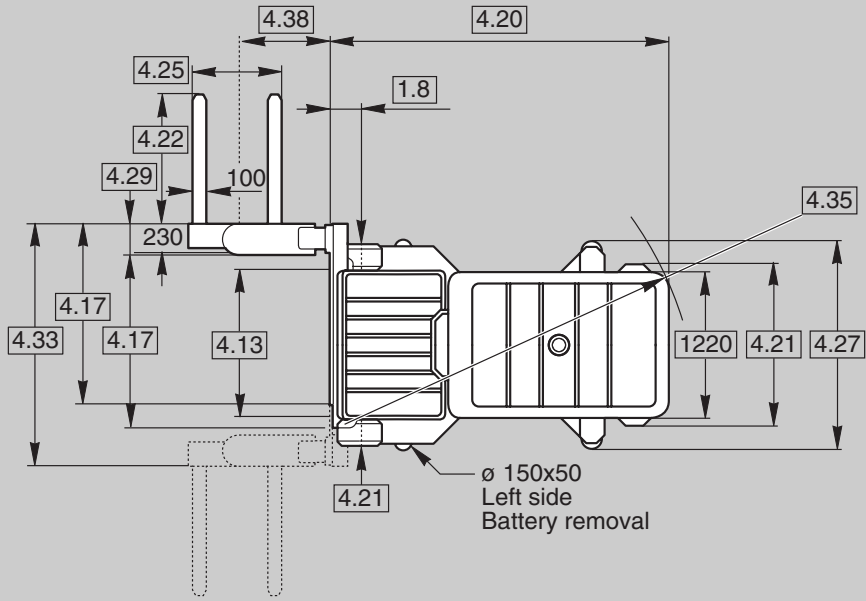

General Information	1.1	Manufacturer	Crown Equipment Corporation			
	1.2	Model				1.8 TS
	1.3	Prime Mover	electric			72 Volt
	1.4	Operator Type				sit-down (man-up)
	1.5	Load Capacity*		Q	t	1.8
	1.6	Load Centre		c	mm	600
	1.8	Load Distance		X	mm	245
	1.9	Wheel Base		y	mm	see table 2
	2.1	Weight	less battery		kg	see table 1
Tyres	3.1	Tyre Type				polyurethane
	3.2	Tyres	front		mm	ø 380 x 205
	3.3	Tyres	rear		mm	ø 330 x 140
	3.4	Additional Wheels	guide rollers		mm	ø 150 x 50
	3.5	Wheels	number (x = driven) front / rear			2 / 2x
	3.6	Track Width	front	b ₁₀	mm	1080 – 1690
	3.7	Track Width	rear	b ₁₁	mm	890
Dimensions	4.2	Mast	collapsed height	h ₁	mm	see table 1
	4.3	Free Lift	TN-mast; TF-mast	h ₂		see table 1
	4.4	Lift Height	(lift + aux. lift)	h ₃	mm	see table 1
	4.5	Mast	extended height	h ₄	mm	see table 1
	4.11	Aux. Lift		h ₉	mm	2055
	4.11a	Aux. Mast Extension			mm	305
	4.13	Cabin Width		b ₉	mm	1220
	4.15	Lowered Fork Height		h ₁₃	mm	75
	4.17	Traverse Frame Width			mm	1225 / 1475
	4.19	Overall Length		l ₁	mm	see table 2
	4.20	Head Length		l ₂	mm	see table 2
	4.21	Width Overall***	front / rear	b ₁ / b ₂	mm	1220 – 1830 / 1220, 1285
	4.22	Fork Dimensions		thxwxl	mm	50 x 100 x 750, 950, 1150
	4.25	Width Across Forks		b ₅	mm	390 – 1365
	4.27	Width Across Guide Rollers		b ₆	mm	32 mm – 220 mm greater than load wheel width in 6.5 mm increments
4.29	Side Shift	per side in increments of 125		mm	100 – 265	
4.32	Ground Clearance	centre wheelbase	m ₂	mm	50	
4.33	Working Aisle Width	in increments of 25	A _{st}	mm	1420 – 1750 • 1675 – 2005	
4.34a	Intersection Aisle Width			mm	see table 2	
4.35	Turning Radius		W _a	mm	2840 / 2940	
4.38	Load Handler Length**	centre of turret line	l ₈	mm	720	
Performance	5.1	Travel Speed****	w. / w. o. load		km/h	9.6 / 9.6
	5.2	Lift Speed	main mast, w. / w. o. load		m/s	0.33 / 0.41
	5.2a	Lift Speed	aux. mast, w. / w. o. load		m/s	0.28 / 0.36
	5.3	Lower Speed	main mast, w. / w. o. load		m/s	0.41 / 0.41
	5.3a	Lower Speed	aux. mast, w. / w. o. load		m/s	0.36 / 0.20
	5.10	Service Brake				electric – hydraulic
Motors	6.1	Traction Motor	60 min. rating		kW	2 x 5
	6.2	Lift Motor	15 % on time		kW	18
	6.2a	Steer Motor	continous rating use		kW	1.3
	6.3	Max. Battery Box Size		lxwxh		see table 2
	6.4	Battery Voltage	nominal capacity 5h		V/Ah	72 / 600 (36x 2) / 72 / 800 (36x 2)
6.5	Battery Weight	min.		kg	see table 2	
Misc.	8.1	Type of controller	drive / lift			Transistor

* Capacity derating is dependant upon combination of load centre, load wheel spread, 180° traverse side shift, battery compartment size, lift height, travel speed, auxiliary mast height, load handler overall length.

** Further variations available in 75 mm increments from 770 mm – 1380 mm.

*** Width overall front in 25 mm increments.available, rear 1220 if front is <1295.

**** Limitations apply. Please read "Electrical" section in the "Technical Information", part of this specification sheet.

Table 1

4.2	Collapsed Height	h ₁	mm	3175	3330	3480	3635	3785	3940	4090	4245	4395	4550	4700	4855	5005	5160	5310
4.3	Free Lift TN △	h ₂	mm	2130	2130	2130	2130	2130	2130	2130	2130	2130	2130	2130	2130	2130	2130	2130
4.3	Free Lift TF ▲	h ₂	mm	2105	2260	2410	2565	2715	2870	3020	3175	3325	3475	3630	3780	3935	4085	4240
4.4	Lift Height ▲	h ₃	mm	5560	5865	6170	6475	6780	7085	7390	7695	8000	8305	8610	8915	9220	9525	9830
4.5	Extended height	h ₄	mm	6630	6935	7240	7545	7850	8155	8460	8765	9070	9375	9680	9985	10290	10595	10900
4.11	Aux. Lift	h ₉	mm	2055	2055	2055	2055	2055	2055	2055	2055	2055	2055	2055	2055	2055	2055	2055
2.1	Weight ■ ● TN/TF		kg	5260	5305	5345	5390	5435	5480	5525	5565	5610	5655	5700	5740	5785	5830	5875

4.2	Collapsed Height	h ₁	mm	5465	5615	5770	5920	6075	6225	6380	6530	6685	6835	6985	7140	7290	7290
4.3	Free Lift TN △	h ₂	mm	2130	2130	2130	2130	2130	2130	2130	2130	2130	2130	2130	2130	2130	2130
4.3	Free Lift TF ▲	h ₂	mm	4390	4545	4695	4850	5000	5155	5305	5460	5610	5765	5915	6070	6220	6525
4.4	Lift Height ▲	h ₃	mm	10135	10440	10745	11050	11350	11655	11960	12265	12570	12875	13180	13485	13790	14095
4.5	Extended height	h ₄	mm	11205	11510	11815	12120	12425	12730	13035	13335	13640	13945	14250	14555	14860	15165
4.11	Aux. Lift	h ₉	mm	2055	2055	2055	2055	2055	2055	2055	2055	2055	2055	2055	2055	2055	2055
2.1	Weight ■ ● TN/TF		kg	5915	5960	6005	6050	6090	6135	6180	6225	6265	6310	6540	6630	6720	6810

■ Truck weight less battery with C-battery compartment and 1220 mm platform width.

● Add 35 kg for D-battery compartment; add 130 kg for platform width 1475 mm

△ Auxiliary lift only

▲ including auxiliary lift

Table 2

		Compartment size	C	D
		ampere hours A/h	600 – 750	600 – 800
6.3	Maximum width battery size	length	400	457
		width	975	982
		height	784	784
4.34a	Intersecting aisle width	1000 x 1200 load width	4700 mm	4800 mm
		1200 x 800 mm load width	4600 mm	4700 mm
4.19	Overall length	mit 720 mm load handler	3910 mm	4000 mm
4.20	Head length		2790 mm	2880 mm
1.9	Wheel base		2255 mm	2345 mm
6.5	Battery weight min.		2x 803 kg	2x 946 kg

* Includes 2 x 100 mm „in aisle“ security clearance.

Note: Chart is based on standard auxiliary lift height = 2055 mm.

Standard Equipment

1. 72-volt fused electrical system.
2. SCR controlled lift and drive motors.
3. Electric power steering.
4. Microprocessor controlled.
5. 350-amp battery connector.
6. Emergency power disconnect.
7. Color-coded wiring.
8. Chain slack sensors.
9. Hour meters independently recording key on, traction, lift, steer and accessories.
10. Start-up time and run time diagnostics.
11. Diagnostic history with optional service terminal.
12. Battery discharge indicator with lift interrupt.
13. Maximum travel speed programmed to meet the application's specs.
14. Gradual reduction in maximum travel speed as primary lift is increased.
15. Swivel seat with height adjustment.
16. Hinged cab door.
17. Key switch.
18. Horn.
19. Two-speedfan.
20. Cab light
21. Work lights.
22. Rear view mirror.
23. Flashing light.
24. Storage pockets.
25. Infinite hydraulic control of raise/lower, traverse and pivot.
26. Manual lowering valve located in power unit.
27. Solid four-point suspension.
28. Rigid tubular mast.
29. Third mast chain.
30. 2-3/4" diameter battery rollers.
31. Dual drive units.
32. Four-wheel braking automatically switched to two-wheel at slower speeds.
33. EGRESS System.

Optional Equipment

1. Wire guidance
2. Rail guidance.
3. End of aisle control system.
4. Extended load handler lengths and carriage widths.
5. Extended auxiliary lift heights.
6. Programmable fork height limits with overrides.
7. Non-marking tires.
8. Power source and mounting brackets for CRT
9. Fire extinguisher.
10. Cold conditioning
11. Additional work lights.
12. Service terminal.

Travel Speeds

Maximum travel speed on guidance is: 9,6 km/h to 3960 mm fork elevation. Gradual speed reduction to 1,6 km/h, above 9445 mm fork elevation. Travel speed is limited to 1,6 km/h under any of the following conditions:

1. Forks are elevated above 305 mm on the auxiliary mast.
2. Forks are not at full pivot.
3. Load handler traverse-sideshift are not at clear-aisle travel position.

Travel speed is disabled under any of the following conditions:

1. Forks are not at full pivot and above 6095 mm.
2. Not on guidance and above 6095 mm.
3. Not on guidance, forks not at clear-aisle travel position above 2360 mm and steering turned greater than 10°.
4. The TN travel speed is disabled, whenever out of guided aisle and primary lift is raised, unless otherwise specified.

Wheels and Tyres

Large, high-load capacity polyurethane press-on tyres. Load wheels – 380 mm diameter x 205 mm wide. Drive wheels – 330 mm diameter x 140 mm wide. Guide wheels – 150 mm diameter x 50 mm wide molded-on hub, non-press-on.

Suspension

Four-point solid suspension with long wheel base and wide spread of load and drive wheels improve truck capacity, reduce effect of uneven floors, and improve floor load distribution.

Forks – Fork Carriage – Turret Carriage

Forks are incrementally adjustable. Fork carriage pivots through 180° permitting pick-up and deposit from either side or front. Cylinders are equipped with hydraulic cushion stops to automatically reduce speed at end of pivot. Cross-over relief valves reduce excess pressure should forks be force-pivoted. Pivot lock engages at full rotated position to prevent drift.

Auxiliary Mast

Turret carriage with forks can be elevated on the auxiliary mast to permit stacking close to ceiling. Operator can view the load from the underside at full auxiliary lift to aid load placement. Lift cylinder, hydraulic hoses, and electrical cables are protected within the profile of the structure, or behind removable covers. Vertical side alignment of the mast is maintained by gear racks and pinions. Lowering of auxiliary and primary lift system will stop if chains become slack.

Traverse and Sideshift

Traverse movement of the auxiliary mast and side movement of the sideshift carriage are automatically sequenced, requiring only one operator control. Full sideshift travel with built-in limits is brought to a smooth stop by hydraulic cushions. Withdrawal of forks from the side-extended position automatically stops at the travel position.

Operator Cabs and Controls

Adjustable operator's seat pivots 35° from a full side position toward a forward position to provide visibility to the front, rear or either side. Lever controls permit all load handling functions to be infinitely controlled. Left hand control is used for primary and auxiliary raise and lower. Right hand pivot and traverse controls can be simultaneously operated for pivoting the load in a minimum amount of space. Movement of the sideshift carriage is automatically sequenced to the traverse control. Integrated palm-pressure buttons in the control knobs require the operator to keep his hands within the compartment during any load handling function. Four programmable fork height limits, t are available for raise and lower. Both lower and one raise limit can be overridden by the operator. Steer wheel position indicator is located next to the steering arm. Forward and reverse travel is controlled by a directional selector and accelerator pedal. The truck can be stopped by activation of foot-operated brake, proportional plugging, parking brake, emergency disconnect or power key. A control and feed-back display includes indicator lights for forward and reverse travel direction, load handler clear aisle

travel position lights, palm switch light, open cab door warning light, master service required light, service calibration light, inductive guidance field strength light (optional), inductive guidance switch and status lights (optional), parking brake switch with status light, fork height limit override button with light and discharge indicator with low voltage lift interrupt to reduce truck and battery maintenance. Controls permitting emergency fork movement are located below the hinged arm rest pad. Horn button, primary power emergency disconnect and power key are provided.

All controls are located convenient to the operator. Storage pockets for work sheets are provided. Two speed fan, cab light and two work lights are located in the overhead consoles.

Primary Mast

Elevated load sway due to mast twisting, plus forward and side bowing are minimized through the use of closed cross-section mast construction. Rolled 'I' beams continuously welded to a flat and a formed plate create a full length, deep cross-section mast capable of resisting front and side loading equally well. Lift cylinders, hoses, cable and chain within the mast are readily accessible for service. Built-in sensors detect slack chain and shut down primary lower, auxiliary lower, pivot and traverse functions.

Drive Units-Steering

Steerable dual drive units with fixed mounted traction motors minimize wear and maintenance on electrical cables. Full electrical power steering uses servomotors for turning the drive wheels. Drive wheels are automatically centred on trucks equipped with aisle-guide rollers.

Brakes

Two force levels of mechanical braking provide smooth stopping at elevated heights. This is achieved by the truck automatically switching from four wheel to two wheel braking at slower travel speeds. Braking can also be accomplished by proportional plugging which permits the operator to control rate of deceleration when extended stopping distance is acceptable.

Electrical

Heavy duty 72 volt electrical power system reduces current requirements for improved efficiency. SCR controlled lift and drive motors. Each controller provides current limiting motor protection in addition to the fuses. Two on board micro-computers are integrated into the truck to provide maximum load handling throughput and smooth truck performance. Serial data link communications between the elevated cab and the lower power unit minimizes the number of electrical conductors through the mast. Long life solid state encoders and LVDT are used in place of potentiometers. Travel speed is sensed and regulated to precise rate. Height sensor provides input for a programmed gradual reduction in maximum allowable travel speed as the primary lift is elevated. Maximum lift and lower speeds are reduced near full lift and lower to provide a soft stop. On-board software includes truck calibration, system diagnostics and trouble isolation capabilities accessible by an optional plug-in terminal.

Hydraulics

Maximum lowering speed is limited by pressure-compensating flow controls and velocity fuses. Integrated hydraulic cylinder cushions soften primary mast staging and bottom stop when lowering. All lift cylinder rams are plated and retract into the hydraulic oil for additional corrosion protection when forks are lowered. Primary mast emergency lowering valve and load handler emergency power switch are located in the power unit.

Safety Regulations

Conforms to European safety standards. Dimensions and performance data given may vary due to manufacturing tolerances. Performance is based on an average size vehicle and is affected by weight, condition of truck, how it is equipped and the conditions of the operating area. Crown products and specifications are subject to change without notice.

