

CROWN

RR 5700 SERIES

Specifications

Reach Trucks



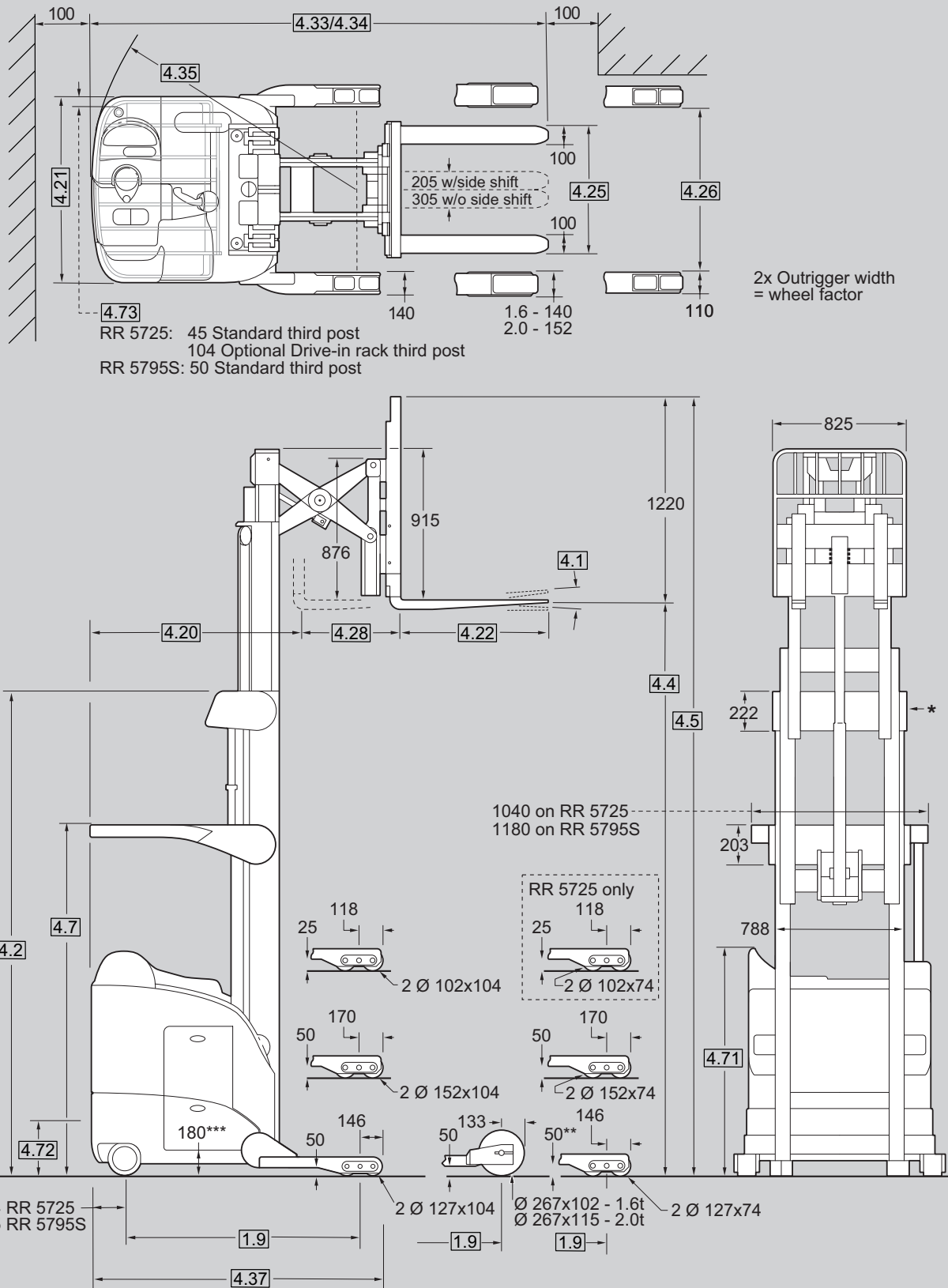

* top tie bar width – 840 for 6095 or 6855 lift height, 890 for 7620 and above
 ** 25 on lift heights above 8150
 *** Height reduces from 180 mm with tyre wear

General Information	1.1	Manufacturer	Crown Equipment Corporation					
	1.2	Model			RR 5725-1.6	RR 5725-2.0	RR 5795S-2.0	
	1.3	Power			electric			
	1.4	Operator Type			stand		sit / stand	
	1.5	Load Capacity *		Q	t	1.6	2.0	2.0
	1.6	Load Centre		c	mm	600		
	1.8	Load Distance	forks retracted	x	mm	390	434	434
	1.9	Wheel Base		y	mm	see table of dimensions 2		
		2.1	Weight	less battery		kg	see table of dimensions 1	
Tyres	3.1	Tyre Type				poly		
	3.2	Tyres	power unit side, drive		mm	Ø 330 x 140		
	3.3	Tyres	load side, standard wheel		mm	Ø 127 x 104		
	3.4	Castor Wheel			mm	Ø 205 x 102	Ø 205 x 102	(2x) Ø 215 x 70
	3.5	Wheels	no. (x = driven) power unit side/load side			1x, 2 / 4	1x, 2 / 4	1x, 3 / 4
	3.7	Track Width	power unit side	b10	mm	808	808	927
	Dimensions	4.1	Fork Carriage Tilt	forward / backward	angle	°	3 / 4	
4.2		Mast	collapsed height	h1	mm	see table of dimensions 1		
4.3		Free Lift		h2	mm	see table of dimensions 1		
4.4		Lift Height		h3	mm	see table of dimensions 1		
4.5		Mast	extended height w.o. load backrest	h4	mm	see table of dimensions 1		
4.7		Overhead Guard Height		h6	mm	see table of dimensions 1		
4.10		Outrigger Height	standard wheel	h8	mm	127 **		
4.20		Headlength		l2	mm	see table of dimensions 2		
4.21		Overall Width	power unit side	b1	mm	1067	1067	1220
4.22		Fork Dimension	standard / optional lengths	thxwxl	mm	45 x 100 x 915 / 762, 990, 1065, 1145, 1220		
4.23		Fork Carriage	DIN 15173 class		mm	2 A		
4.24		Fork Carriage Width	incl. load backrest	b3	mm	825		
4.25		Width Across Forks	w. sidershifter / w.o. sidershifter	b5	mm	200-685 / 305-760		
4.26		Inside Straddle	in 25 mm increments	b4	mm	865 - 1270		
4.28		Reach		l4	mm	590		
4.32		Ground Clearance	centre wheelbase	m2	mm	25 - 50, see diagram		
4.33		Working Aisle Width	1000 x 1200	Ast	mm	see table of dimensions 2		
4.34		Working Aisle Width	800 x 1200	Ast	mm	see table of dimensions 2		
4.35		Turning Radius		Wa	mm	see table of dimensions 2		
4.37		Overall Length	length over outriggers	l7	mm	see table of dimensions 2		
4.71		Backrest Height			mm	1460	1460 to 1590	
4.72	Entry Step Height			mm	240	250		
4.73	3rd Post	standard		mm	45	50		
Performance	5.1	Travel Speed - Standard	w. / w.o. load power unit first		km/h	12 / 13	12 / 13.3	
	forks first			km/h	9 / 11	10 / 11		
	5.2	Lift Speed	w. / w.o. load		m/s	0.48 / 0.80	0.42 / 0.78	0.42 / 0.78
	5.3	Lower Speed	w. / w.o. load		m/s	0.56 / 0.56		
	5.4	Reach Speed	adjustable		m/s	0.10 - 0.30		
5.10	Brakes	applied / released			mechanical / electrical			
Motors	6.1	Traction Motor	60 min. rating		kW	4.8		
	6.2	Lift Motor	15% on time		kW	20.5		
	6.3	Max. Battery Box Size		lxhxw	mm	see table of dimensions 2		
	6.4	Battery Voltage	nominal capacity 5 h rating		V/Ah	36 / see table of dimensions 2		
	6.5	Battery Weight	minimum		kg	see table of dimensions 2		
			Battery removal			both sides	both sides	drive side
	8.1	Type of Controller	traction / lift / steering			AC		

* Contact factory. Capacity may be subject to derating at height

** Above h3 = 8150 standard wheel is Ø 152 mm

Table 1

Type		RR 5725-1.6 / RR 5725-2.0 / RR 5795S-2.0						
4.2	Mast	collapsed height	mm	2260	2415	2720	3025	3330
4.3	Free Lift*	w.o. load backrest	mm	1345	1495	1800	2105	2410
4.4	Lift Height		mm	5025	5330	6095	6855	7620
4.5	Mast*	extended height w.o. load backrest	mm	5945	6250	7010	7775	8535
4.7	Height	overhead guard	mm	2260	2415	2415	2415	2415
	Minimum Straddle OD	width across outriggers	mm	1070				
2.1	Truck Weight less battery	compartment size						
			kg	2475	2515	2630	2740	2820
	RR 5725-1.6	C	kg	2650	2700	2840	2970	3200
		D	kg	2670	2715	2860	2990	3220
		E	kg	2690	2740	2885	3015	3245
	RR 5795S-2.0	C	kg	2800	2850	2990	3120	3350
		D	kg	2820	2870	3015	3145	3375
		E	kg	2845	2890	3035	3170	3400

Type		RR 5725-2.0 / RR 5795S-2.0				RR 5795S-2.0			
4.2	Mast	collapsed height	mm	3560	3785	4065	4370	4525	4830
4.3	Free Lift*	w.o. load backrest	mm	2640	2870	3150	3450	3605	3911
4.4	Lift Height		mm	8150	8660	9295	10160	10695	11225
4.5	Mast*	extended height w.o. load backrest	mm	9070	9575	10210	11075	11610	12140
4.7	Height	overhead guard	mm	2415					
	Minimum Straddle OD	width across outriggers	mm	1070	1245	1270	1345	1345	1345
2.1	Truck Weight less battery	compartment size							
		C	kg	3280	-	-	-	-	-
		D	kg	3300	3415	-	-	-	-
	RR 5795S-2.0	E	kg	3325	3440	3535	3645	-	-
		C	kg	3435	-	-	-	-	-
		D	kg	3455	3615	-	-	-	-
	E	kg	3480	3640	3740	3845	4060	4225	

Table 2

		RR 5725-1.6	RR 5725-2.0			RR 5795S-2.0			
Compartment		C	C	D	E	C	D	E	
1.9	Wheel base	y	1428	1513	1557	1624	1513	1557	1624/1745 ▲
4.20	• Headlength	l2	1300	1345	1390	1455	1395	1440	1505/1625 ▲
4.33	• 1200 x 1000 deep	Ast	2787	2807	2850	2914	2850	2893	2957/3084 ▲
4.33	• 1000 x 1200 deep	Ast	2883	2897	2940	3004	2940	2983	3047/3174 ▲
4.34	• 800 x 1200 deep	Ast	2835	2847	2890	2954	2890	2933	2997/3124 ▲
4.35	Turning Radius	Wa	1732	1783	1826	1890	1826	1869	1933/2060 ▲
4.37	Overall Length	L7	1838	1923	1967	2034	1974	2018	2085/2206 ▲
6.3	Max. Battery Box	lxwxh	412x974x785	412x974x785	457x982x785	525x982x785	412x974x785	457x982x785	525x982x785
6.4	Battery max.	Ah	750	750	800	900	750	900	1000
6.5	Battery min.	kg	908	908	1035	1180	910	1040	1180/1270 ▲

* Subtract 305 mm from free lift, and add 305 mm to extended height for all models if standard load backrest 1220 mm is required

▲ Applies to 11225 mm lift height, extended chassis

• Add 50 mm with optional sideshift

Capacity

Model RR 5725-1.6: 1600 kg at 600 mm load center, 36 volt
 Model RR 5725-2.0: 2000 kg at 600 mm load center, 36 volt
 Model RR 5795S-2.0: 2000 kg at 600 mm load center, 36 volt

Batteries

Standard battery compartment rollers for extraction with mechanised equipment.

Standard Equipment

1. Crown's Access 1 2 3® Comprehensive System Control
2. 36 volt system
3. AC Traction System
4. OnTrac™ Anti-Slip Traction Control
5. AC Hydraulic System
6. Electronic power steering
7. Operator Compartment
 - Variable side stance
 - Flexible five-point positioning
 - Back support with integral hip support
 - Arm/elbow support padding
 - Padded compartment interior walls
 - Operator console with work surface and storage
 - Suspended floor
 - Entry bar
 - Premium urethane floorboard cushion
 - Console light
8. Multi-task control handle
9. Crown display
 - Event code display with five (5) key navigation.
 - Hour meters / travel distance / stop watch
 - PIN Code access capable
 - Access 1 2 3 diagnostics
 - P1, P2, P3 performance tuning
 - Battery discharge indicator, steer wheel direction indicator, OnTrac Traction Control indicator

10. High visibility power unit
11. High visibility mast
12. Overhead guard
13. 1220 mm high load backrest
14. Tilting fork carriage
15. Tandem articulating load wheels
16. Lift slow down 300 mm from maximum lift height
17. Lift Limit without override
18. Crown-manufactured AC drive and lift motors
19. Offset articulated drive axle with 190° steer arc
20. Key switch
21. Horn
22. Emergency power disconnect
23. SBE 320 amp grey battery connector
24. Large diameter battery rollers
25. Colour-coded wiring
26. Third post
27. InfoPoint® component identification system

Model Specific Standard Equipment
RR 5725

1. Battery removal from left or right side of truck on RR 5725 series.
2. 1740 cm² suspended floorboard area

RR 5795S

1. Battery removal from left side of truck
2. 2470 cm² suspended floorboard area and 1150 cm² upper footrest area
3. Adjustable suspended seat, lean seat, backrest, and multi-task control armrest
4. Adjustable steer tiller

Optional Equipment

1. Rack Height Select and Tilt Position Assist
2. Capacity monitor
3. Camera and colour monitor
4. Lift limit with override
5. Drive-in rack cylinder package

6. Drive-in rack mast (RR 5725 2.0 t only)
7. Drive-in rack third post
8. Chain slack kit
9. Removable outrigger tips
10. Mesh screen mast guard
11. Battery retainer with interlock
12. 5th battery compartment roller
13. 915 mm and 1065 mm high load backrests
14. Crown-manufactured sideshifter, 50 mm or 100 mm each way
15. Overhead guard mesh
16. Fork lengths
17. Work lights
18. Corrosion/freezer conditioning (freezer conditioning includes a 16 mm thick power unit skirt with extended coverage of the drive and caster tyres)
19. Load wheel sizes and compounds
20. Work Assist™ Accessories:
 - Accessory tube
 - Accessory RF mounting plate
 - Accessory RF mounting bracket
 - Accessory clamp
 - Accessory clip pad
 - Accessory hook
 - Accessory clip pad and hook
 - Accessory pocket

Operator Compartment

Soft, rounded surfaces make compartment interior more comfortable. Streamlined exterior smooths entry/exit for the operator. A low, walk-in floor height, speeds up entry and exit. A patented suspended floorboard provides comfortable footing.

The brake pedal design allows variable side-stance positions for the operator. The operator can change positions to increase comfort and productivity.

Five-point positioning provides control and stability, starting with the right hand on the multi-task controller and the left hand on the steer tiller. Left foot on the brake pedal and the right foot on the presence sensor. The operator's back is naturally fitted against the wrap-around support cushion.

An entry bar with sensors to automatically slow truck travel, encourages safe foot positioning inside the truck.

The multi-task control enables the operator to manoeuvre the truck while blending lift and accessory functions for improved productivity. Control handle activation forces are reduced. The soft grip steer tiller with electronic power steering reduces operator fatigue.

Operator visibility is improved with:

- Low profile power unit
- High visibility mast
- Angled mast cross bracing
- Angled overhead guard cross bars
- Variable side stance

Superior thermal management is the result of several design features: reduced heat generating components, positioning of heat generating components away from the compartment, padding to insulate the compartment from heat, and improved air paths through the truck.

Clipboard surface and console storage pockets are standard. Additional S-Class specific operator compartment features: All S Class reach trucks include an upper footrest area, with smart foot presence pedal and brake control. Using these large, exclusive footrests can improve operator comfort. From the standing position, the ability to lift either leg to a footrest can reduce fatigue which increases productivity.

The S Class model offers a superior level of flexibility for the operator with an adjustable suspended seat, lean seat, backrest, armrest, control handle and steer tiller. The combination of these features lets the operator move from a standing, leaning or seated driver position. By changing postures and using different sets of muscles, significant ergonomic, physiological and orthopedic benefits may result.

Crown's Access 1 2 3® Comprehensive System Control provides optimum performance and control by offering a communication interface for operators and technicians, intelligent coordination of lift truck systems and simplified service with advanced diagnostics.

The Crown display is used for easy trouble shooting, accessing service history and setting performance features. There is no laptop with specific software or service handset required for troubleshooting or parameter adjustments. A distribution panel is conveniently located with all test points, control fuses and central wiring for easy troubleshooting.

Three modes of performance can be selected to accommodate operator experience or application requirements.

OnTrac™ Anti-Slip Traction Control

Crown's Access 1 2 3 technology monitors truck dynamics, optimises traction, reduces spinning during acceleration, prevents lock-up during braking, and greatly extends tyre life.

Travel

Crown's AC traction system is a closed loop traction control system that maintains top speed throughout the battery charge. Access 1 2 3 supplies the operator with a "fresh from the charger" feeling throughout the whole battery charge cycle. Engineered and manufactured by Crown, the AC motor, controller and drive unit are designed specifically for lift truck applications.

On a slope or when interfacing with push-back racking, the "truck hold" feature electronically brakes the truck when the handle is in neutral. Selected travel speed remains constant regardless of surfaces, load weight or grades. Less throttling of control handle means better truck control and less fatigue to the operator.

Steering

The electronic power steering uses an AC steer motor and steering control module integrated with the Access 1 2 3 System to provide fast, reliable steering response. Smooth, quiet and responsive steering control with minimal operator effort. Steer tyre rotates 190° for maximum manoeuvrability.

Braking

A disc brake on the motor armature shaft combined with motor regenerative braking provides sure braking with fewer parts and maintenance requirements. The offset, articulated drive-unit design improves drive tyre brake force. Regenerative motor braking helps save energy, and decreases motor temperature.

An additional electronically-applied brake on both castor wheels work with the motor brake to provide excellent brake performance for the S Class truck.

Load Handling

The optional load handling assist package provides rack height select and tilt position assist features.

The Rack Height Select feature allows the forks to be programmed to stop at preselected heights. With one-touch of the multi-task trigger while lifting or lowering, the mast will stop at the next programmed height.

Another useful option is the Tilt Position Assist. This allows the fork tilt to stop at a horizontal position for maximum fork clearance when entering pallets. Also optional, the Capacity Monitor shows the approximate weight on the forks and the fork height. It will alert the operator when the truck capacity is exceeded for the fork height. It will also show how high or to which lift zone you can raise the load.

Mast

High visibility mast design with angled cross bracing and angled overhead guard braces improve visibility for high or low stacking.

Crown's patented staging cushions coupled with lowering dampers and speed reductions at maximum lift improve overall load handling control.

Rolled steel outer channel masts and inner "I" beams roll on canted, steel, anti-friction roller bearings for minimal current draw and long life.

Telescoping mast sections are staggered to reduce truck length. Heavier mast cross bracing design increases stiffness. Above 6860 mm lift height, vertical mast reinforcement maintains maximum capacity.

Reach Mechanism

Inner arm has a one piece plate with continuous welding. Torque plate is also used to give the mechanism stiffness to resist twisting for long-lasting durability. Outer arms are designed with large heel to provide more material for stresses to be distributed evenly. Robotically welded for maximum strength.

Carriage

A hook-type carriage conforming to ITA / FEM / ISO Class 2A specifications is used. Load backrest is standard.

Safety Regulations

Conforms to European safety standards.

Dimensions and performance data given may vary due to manufacturing tolerances. Performance is based upon an average size vehicle and is affected by weight, condition of truck, how it is equipped and the conditions of the operating area. Crown products and specifications are subject to change without notice.

