

CROWN

WE 2300 SERIES

Profile Sheet

Walkie Forkover Stacker



WE 2300 Series

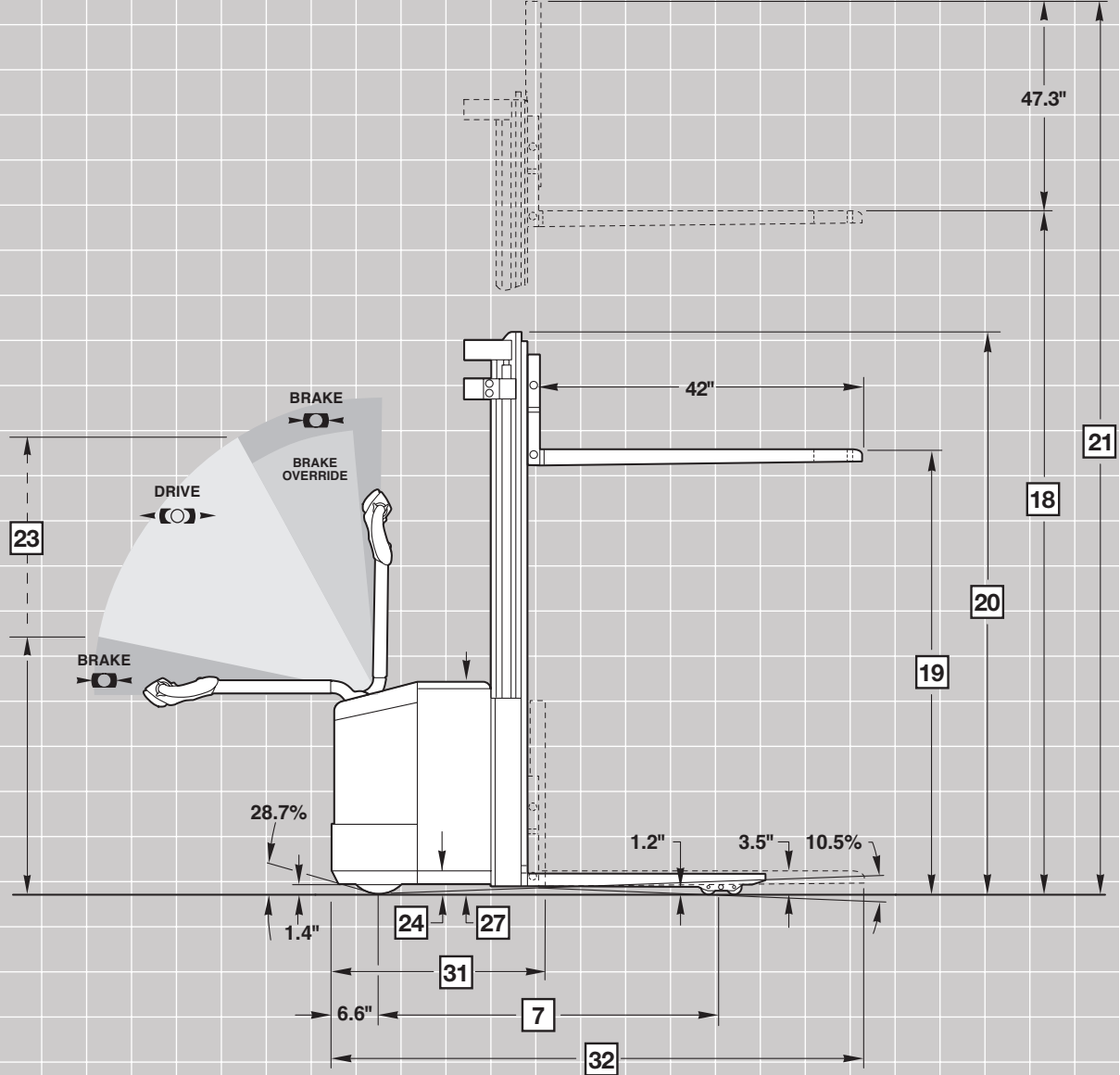
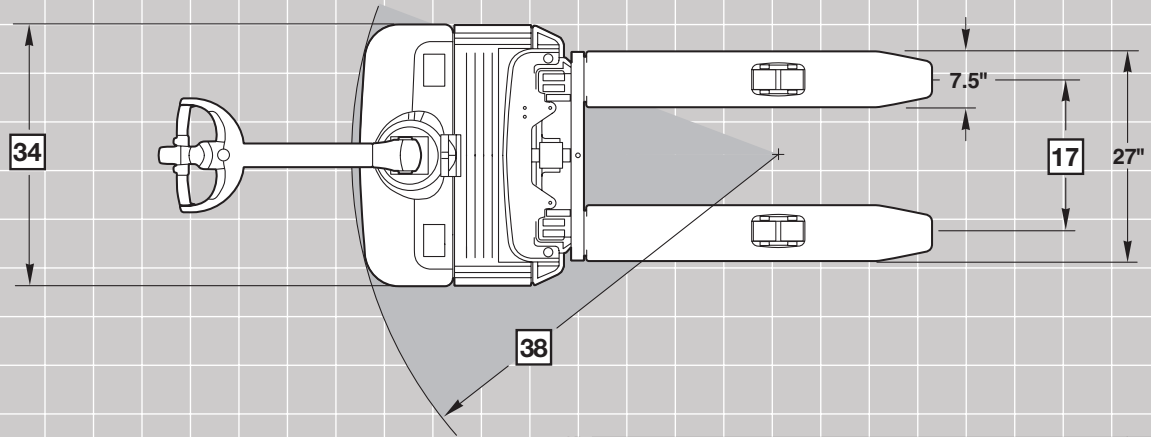

WE 2300 Series

General Information	1	Manufacturer		Crown Equipment Corporation		
	2	Model		WE 2300-25	WE 2300-30	
		Mast Type		TL	TF	
	3	Power		Electric		
	4	Operator Type		Walkie		
	5	Load Capacity	Max	lb (kg)	2500 (1135)	3000** (1361**)
	6	Load Center		in (mm)	24 (600)	24 (600)
	7	Wheelbase		in (mm)	47 (1206)	50 (1280)
Tires	8	Weight	Less Battery	lb (kg)	1907 (865)	2072 (940)
	13	Wheel Size Front (d x w)	Vulkollan	in (mm)	9.8 x 3 (250 x 75)	
	14	Wheel Size Rear (d x w)	Vulkollan	in (mm)	3.2 x 4 (82 x 100)	3.2 x 2.3 (82 x 60)
	15	Additional Wheels	Caster Wheel (d x w)	in (mm)	5.9 x 2 (150 x 50)	
	16	Wheels (x=driven)	Front/Rear		1x, 1/2	1x, 1/4
Dimensions	17	Track Width	Front	in (mm)	23 (587)	
	Rear		in (mm)	15 (382)		
	18	Lift Height		in (mm)	130 (3300)	130 (3300)
	19	Free Lift	w/o Load Backrest	lb (kg)	6 (150)	68 (1720)
	20	Collapsed Height		in (mm)	84 (2130)	84 (2130)
	21	Extended Height*	w/o Load Backrest	in (mm)	147 (3730)	147 (3730)
	22	Load Backrest Size		in (mm)	47.3 (1202) H x 32.7 (832) W	
	23	Tiller Arm Height in Drive Position	Min/Max	in (mm)	31 (780) / 48 (1220)	
	24	Battery Comp't Floor Ht		in (mm)	3.4 (85)	
	25	Lowered Fork Height		in (mm)	3.5 (90)	
	27	Power Unit Height		in (mm)	29.75 (756)	
	28	Fork Lengths		in (mm)	42 (1067)	
	29	Fork Dimensions	Thickness	in (mm)	2 (50)	
			Width	in (mm)	7.5 (190)	
	30	Width Across Forks		in (mm)	27 (686)	
	31	Headlength		in (mm)	29 (730)	30 (753)
	32	Overall Length	at fork length 42"	in (mm)	71 (1803)	72 (1829)
	34	Overall Width		in (mm)	33.5 (850)	
	35	Fork Carriage Width		in (mm)	27 (680)	
	36	Ground Clearance	w/Load Below Mast	in (mm)	1.4 (35)	
37	Center Wheelbase		in (mm)	1.2 (30)		
38	Turning Radius		in (mm)	55 (1400)	58 (1475)	
Gradeability	43	Gradeability	w/wo Load, 30 min Rating	%	3 / 9	3 / 8
	44	Maximum Gradeability	w/wo Load, 5 min Rating	%	9 / 17	8 / 17
	45	Service Brake			Electric	
Battery	46	Maximum Battery Box	L x W x H	in (mm)	8.5 x 32.5 x 24.7 (216 x 827 x 627)	
	47	Battery Voltage (Nominal Capacity 6 Hour Rating)	MF battery pack***	V/Ah	24 / 195	
	48	Type of Controller	Drive		Transistor	
	49	Battery Weight		lb (kg)	644-712 (293-323)	

* Subtract 32" (810 mm) from free lift; add 32" (810 mm) to extended height if optional 47.3" (1202 mm) high load backrest is required.

** Up to 110" (2800 mm), 2910 lb up to 130" (3300 mm)

*** Maintenance free battery pack option, includes charger.

English conversions are approximations. Metric conversions should be done to find true values.



Crown Equipment Corporation
 New Bremen, Ohio 45869 USA
Tel 419-629-2311
Fax 419-629-3796
 crown.com

You can count on Crown to build lift trucks designed for safe operation, but that's only part of the safety equation. Crown encourages safe operating practices through ongoing operator training, safety-focused supervision, maintenance and a safe working environment. Go to crown.com and view our safety section to learn more.

Because Crown is continually improving its products, specifications are subject to change without notice.

Crown, the Crown logo, the color beige, the Momentum symbol and The X10 Handle are trademarks of Crown Equipment Corporation.

Copyright 2012 Crown Equipment Corporation
 SF18789 01/12
 Printed in U.S.A.