

**CROWN**

# C-D<sup>x</sup>

**2,000–3,500 kg Capacity**

NXP Model

IC Pneumatic Tyre

## Specifications



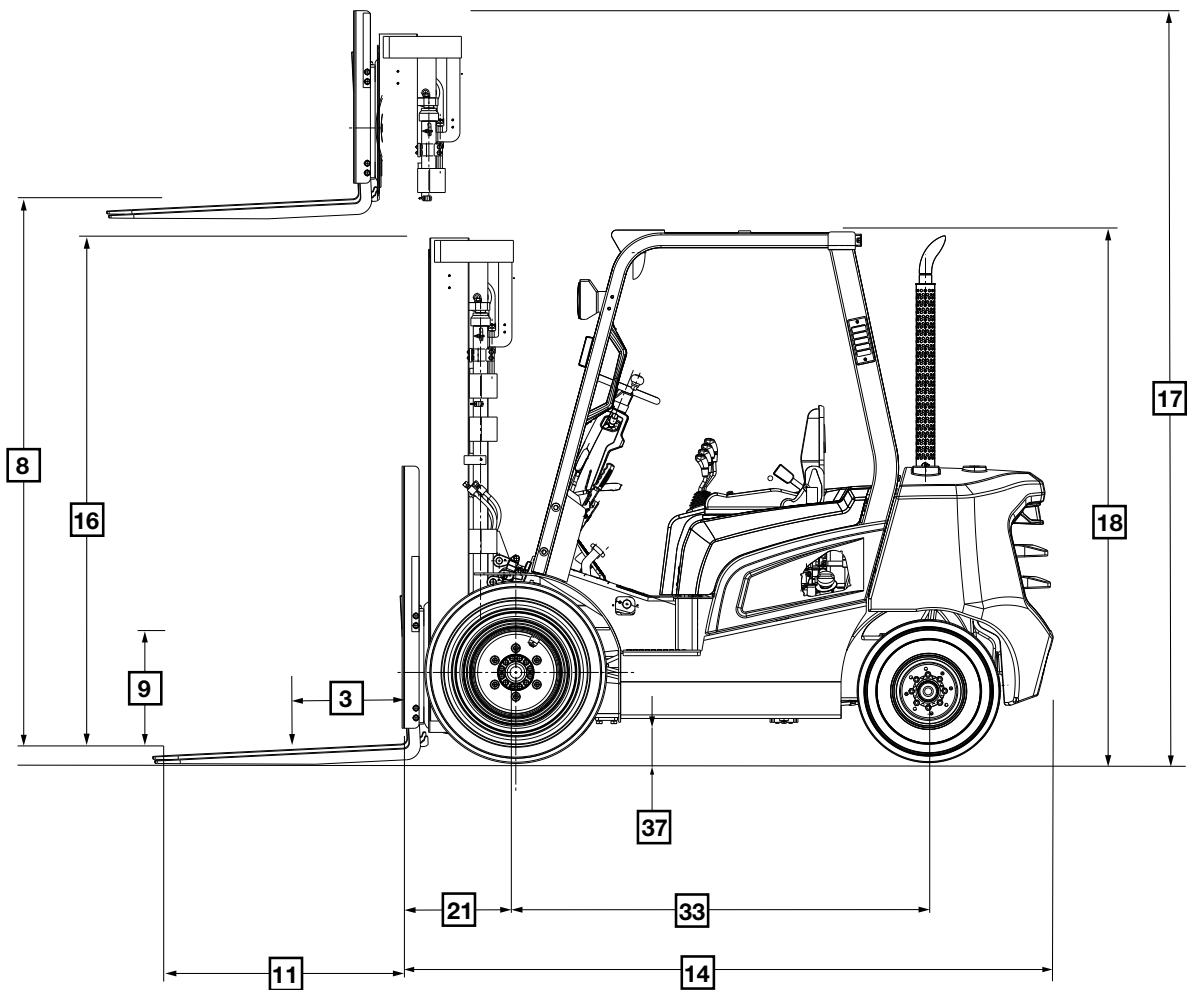
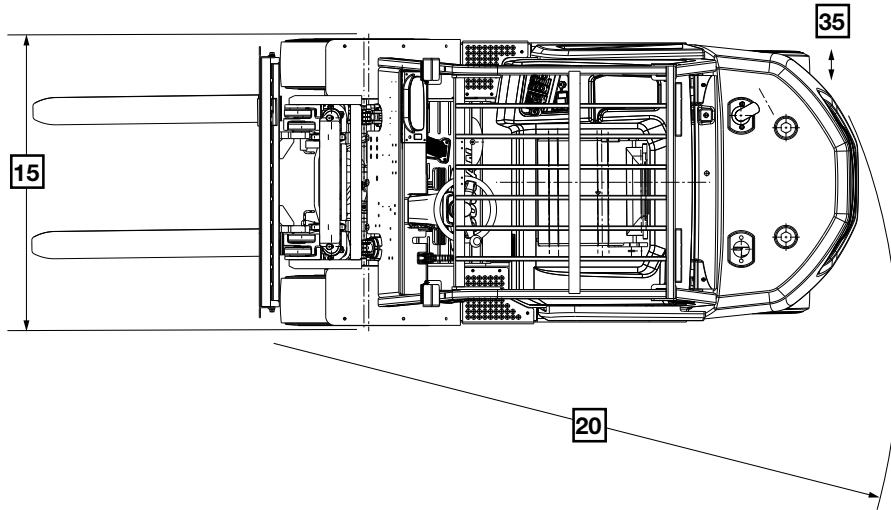

# C-D<sup>x</sup> Series

# Specifications

|                 |                      |                                   | CD20NXP                              | CD25NXP  | CD30NXP               | CD33NXP               | CD35NXP               |                       |                       |
|-----------------|----------------------|-----------------------------------|--------------------------------------|----------|-----------------------|-----------------------|-----------------------|-----------------------|-----------------------|
| Characteristics | 1                    | <b>Model</b>                      |                                      |          |                       |                       |                       |                       |                       |
|                 | 2                    | <b>Load Capacity</b>              | At Rated Load Centre                 | kg       | 2,000                 | 2,500                 | 3,000                 | 3,300                 | 3,500                 |
|                 | 3                    | <b>Load Centre</b>                |                                      | mm       | 500                   | 500                   | 500                   | 500                   | 500                   |
|                 | 4                    | <b>Power Type</b>                 | Elec, Diesel, LPG, Petrol            |          | Diesel                | Diesel                | Diesel                | Diesel                | Diesel                |
|                 | 5                    | <b>Operator Type</b>              |                                      | Sit-down | Sit-down              | Sit-down              | Sit-down              | Sit-down              | Sit-down              |
|                 | 6                    | <b>Tyre Type</b>                  | P:Pneumatic                          | P        | P                     | P                     | P                     | P                     | P                     |
|                 | 7                    | <b>Wheels (x = driven)</b>        | Front / Rear                         | x 2 / 2  | x 2 / 2               | x 2 / 2               | x 2 / 2               | x 2 / 2               | x 2 / 2               |
| Dimensions      | 8                    | <b>Maximum Fork Ht.</b>           | with Std 2-Stage Mast                | mm       | 3,000                 | 3,000                 | 3,000                 | 3,000                 | 3,000                 |
|                 | 9                    | <b>Free Lift</b>                  |                                      | mm       | 150                   | 150                   | 150                   | 150                   | 150                   |
|                 | 10                   | <b>Fork Carriage</b>              | ISO Class                            |          | II                    | II                    | III                   | III                   | III                   |
|                 | 11                   | <b>Forks</b>                      | Length x Width x Thickness           | mm       | 1050x100x45           | 1050x100x45           | 1050x122x45           | 1050x125x45           | 1050x125x45           |
|                 | 12                   |                                   | Fork Carriage Width                  | mm       | 1,042                 | 1,042                 | 1,042                 | 1,042                 | 1,042                 |
|                 | 13                   | <b>Tilt of Mast</b>               | Forward / Backward                   | deg      | 6 / 10                | 6 / 10                | 6 / 10                | 6 / 10                | 6 / 10                |
|                 | 14                   | <b>Overall Dimensions</b>         | Length to Fork Face                  | mm       | 2,560                 | 2,610                 | 2,665                 | 2,730                 | 2,750                 |
|                 | 15                   |                                   | Overall Width                        | mm       | 1,290                 | 1,290                 | 1,290                 | 1,290                 | 1,290                 |
|                 | 16                   |                                   | Mast Lowered Height                  | mm       | 2,053                 | 2,053                 | 2,053                 | 2,053                 | 2,053                 |
|                 | 17                   |                                   | Mast Extended Height*                | mm       | 4,247                 | 4,247                 | 4,247                 | 4,247                 | 4,247                 |
|                 | 18                   |                                   | Overhead Guard Height                | mm       | 2,160                 | 2,160                 | 2,160                 | 2,160                 | 2,160                 |
|                 | 19                   |                                   | Seat Height                          | mm       | 1,185                 | 1,185                 | 1,185                 | 1,185                 | 1,185                 |
|                 | 20                   | <b>Turning Radius</b>             | Minimum Outside                      | mm       | 2,280                 | 2,330                 | 2,415                 | 2,460                 | 2,480                 |
| 21              | <b>Load Distance</b> | Centre of Drive Axle to Fork Face | mm                                   | 477      | 477                   | 482                   | 487                   | 487                   |                       |
| Performance     | 22                   | <b>Travel Speed</b>               | Loaded / Unloaded                    | km/h     | 20 / 21               | 20 / 21               | 20 / 21               | 20 / 21               | 20 / 21               |
|                 | 23                   | <b>Lifting Speed</b>              | Loaded / Unloaded                    | mm/s     | 580 / 600             | 570 / 600             | 560 / 600             | 480 / 500             | 460 / 480             |
|                 | 24                   | <b>Lowering Speed</b>             | Loaded / Unloaded                    | mm/s     | 485 / 560             | 485 / 560             | 485 / 560             | 470 / 495             | 470 / 495             |
|                 | 25                   | <b>Max Drawbar Pull</b>           | Loaded / Unloaded                    | N        | 21,085 / 20,060       | 20,893 / 19,990       | 20,655 / 19,876       | 20,530 / 19,820       | 20,461 / 19,803       |
|                 | 26                   | <b>Max Gradeability</b>           | Loaded / Unloaded                    | %        | 41 / 66               | 32 / 60               | 28 / 50               | 26 / 47               | 25 / 45               |
| Weight          | 27                   | <b>Total Weight</b>               | Unloaded                             | kg       | 3,635                 | 3,920                 | 4,385                 | 4,585                 | 4,685                 |
|                 | 28                   | <b>Axle Load</b>                  | Loaded, Front / Rear                 | kg       | 4,925 / 710           | 5,560 / 860           | 6,475 / 910           | 6,935 / 950           | 7,205 / 980           |
|                 | 29                   |                                   | Unloaded, Front / Rear               | kg       | 1,705 / 1,930         | 1,720 / 2,200         | 1,785 / 2,600         | 1,720 / 2,865         | 1,650 / 3,035         |
| Chassis         | 30                   | <b>Tyres</b>                      | Size, Front Single                   |          | 28x9-15-14PR          | 28x9-15-14PR          | 28x9-15-14PR          | 28x9-15-14PR          | 28x9-15-14PR          |
|                 | 32                   |                                   | Size, Rear                           |          | 6.50-10-10PR          | 6.50-10-10PR          | 6.50-10-10PR          | 6.50-10-10PR          | 6.50-10-10PR          |
|                 | 33                   | <b>Wheelbase</b>                  | Distance                             | mm       | 1,700                 | 1,700                 | 1,700                 | 1,700                 | 1,700                 |
|                 | 34                   | <b>Tread Width</b>                | Front                                | mm       | 1,060                 | 1,060                 | 1,060                 | 1,060                 | 1,060                 |
|                 | 35                   |                                   | Rear                                 | mm       | 980                   | 980                   | 980                   | 980                   | 980                   |
|                 | 36                   | <b>Ground Clearance</b>           | Loaded at the lowest point           | mm       | 132                   | 132                   | 132                   | 132                   | 132                   |
|                 | 37                   |                                   | Loaded at centre of wheelbase        | mm       | 135                   | 135                   | 135                   | 135                   | 135                   |
|                 | 38                   | <b>Brakes</b>                     | Service                              |          | Hydraulic             | Hydraulic             | Hydraulic             | Hydraulic             | Hydraulic             |
|                 | 39                   |                                   | Parking                              |          | Ratchet               | Ratchet               | Ratchet               | Ratchet               | Ratchet               |
| Power Train     | 40                   | <b>Battery</b>                    | Voltage / Ampere                     | V/AH     | 12 / 90               | 12 / 90               | 12 / 90               | 12 / 90               | 12 / 90               |
|                 | 41                   | <b>Engine</b>                     | Manufacturer / <b>YANMAR</b>         |          | 4TNE98                | 4TNE98                | 4TNE98                | 4TNE98                | 4TNE98                |
|                 | 42                   |                                   | Rated Power (DIN)                    | kW@rpm   | 43.7@2,300            | 43.7@2,300            | 43.7@2,300            | 43.7@2,300            | 43.7@2,300            |
|                 | 43                   |                                   | Maximum Torque                       | n_m@rpm  | 181@1,600             | 181@1,600             | 181@1,600             | 181@1,600             | 181@1,600             |
|                 | 44                   |                                   | Cycle / Cylinders / Displacements CC |          | 4 / 4 / 3,319         | 4 / 4 / 3,319         | 4 / 4 / 3,319         | 4 / 4 / 3,319         | 4 / 4 / 3,319         |
|                 | 45                   | <b>Transmission</b>               | Type                                 |          | Powershift Electrical | Powershift Electrical | Powershift Electrical | Powershift Electrical | Powershift Electrical |
|                 |                      |                                   | Number of Speeds (Fwd / Rev)         |          | 1 / 1                 | 1 / 1                 | 1 / 1                 | 1 / 1                 | 1 / 1                 |
| 46              | <b>Attachments</b>   | Oil Volume                        | lpm                                  | 65       | 65                    | 65                    | 65                    | 65                    |                       |
|                 |                      | Operating Pressure                | bar                                  | 160      | 160                   | 160                   | 160                   | 160                   |                       |

Dimensions based on a TL 2-Stage mast.

Note: Specification values quoted in this specification sheet have been rounded. Performance may vary due to operation conditions. Products and specifications are subject to improvement and change without prior notices.

\* Extended height to top of mast does include load backrest.

**Mast Chart CD20NXP**

| Mast Type | Maximum Fork Height | Maximum Lowered Height | Fully Extended Height | Free Lift | Rated Load Capacities |                     |               |     |               |       |                 |               |
|-----------|---------------------|------------------------|-----------------------|-----------|-----------------------|---------------------|---------------|-----|---------------|-------|-----------------|---------------|
|           |                     |                        |                       |           | With Load Backrest*   | With Load Backrest* | Tilt Angle    |     |               |       | Load Capacities |               |
|           |                     |                        |                       |           |                       |                     | Single Pneum. |     | Double Pneum. |       | Single Pneum.   | Double Pneum. |
|           |                     |                        |                       |           |                       |                     | FWD           | BWD | FWD           | BWD   | LC 500 mm       | LC 500 mm     |
|           |                     |                        |                       | deg       | deg                   | deg                 | deg           | kg  | kg            |       |                 |               |
| TL        | 3,000               | 2,045                  | 4,247                 | 150       | 6                     | 10                  | 6             | 10  | 2,000         | 2,000 |                 |               |
|           | 3,300               | 2,195                  | 4,547                 | 150       | 6                     | 10                  | 6             | 10  | 2,000         | 2,000 |                 |               |
|           | 3,500               | 2,295                  | 4,747                 | 150       | 6                     | 10                  | 6             | 10  | 2,000         | 2,000 |                 |               |
|           | 4,000               | 2,595                  | 5,347                 | 150       | 6                     | 6                   | 6             | 6   | 2,000         | 2,000 |                 |               |
|           | 4,500               | 2,845                  | 5,847                 | 150       | 6                     | 6                   | 6             | 6   | 2,000         | 2,000 |                 |               |
|           | 5,000               | 3,095                  | 6,347                 | 150       | 6                     | 6                   | 6             | 6   | 2,000         | 2,000 |                 |               |
| TF        | 3,210               | 2,155                  | 4,474                 | 950       | 6                     | 10                  | 6             | 10  | 2,000         | 2,000 |                 |               |
| TT        | 4,270               | 2,005                  | 5,554                 | 800       | 6                     | 6                   | 6             | 6   | 2,000         | 2,000 |                 |               |
|           | 4,710               | 2,145                  | 5,974                 | 940       | 6                     | 6                   | 6             | 6   | 1,950         | 2,000 |                 |               |
|           | 5,540               | 2,495                  | 6,799                 | 1,290     | 6                     | 6                   | 6             | 6   | 1,800         | 1,870 |                 |               |
|           | 5,990               | 2,645                  | 7,249                 | 1,440     | 6                     | 6                   | 6             | 6   | 1,300         | 1,800 |                 |               |
|           | 7,060               | 3,145                  | 8,298                 | 1,940     | 6                     | 6                   | 6             | 6   | 600           | 1,500 |                 |               |

\* Based on 1156 mm LBR

**Mast Chart CD25NXP**

| Mast Type | Maximum Fork Height | Maximum Lowered Height | Fully Extended Height | Free Lift | Rated Load Capacities |                     |               |     |               |       |                 |               |
|-----------|---------------------|------------------------|-----------------------|-----------|-----------------------|---------------------|---------------|-----|---------------|-------|-----------------|---------------|
|           |                     |                        |                       |           | With Load Backrest*   | With Load Backrest* | Tilt Angle    |     |               |       | Load Capacities |               |
|           |                     |                        |                       |           |                       |                     | Single Pneum. |     | Double Pneum. |       | Single Pneum.   | Double Pneum. |
|           |                     |                        |                       |           |                       |                     | FWD           | BWD | FWD           | BWD   | LC 500 mm       | LC 500 mm     |
|           |                     |                        |                       | deg       | deg                   | deg                 | deg           | kg  | kg            |       |                 |               |
| TL        | 3,000               | 2,045                  | 4,247                 | 150       | 6                     | 10                  | 6             | 10  | 2,500         | 2,500 |                 |               |
|           | 3,300               | 2,195                  | 4,547                 | 150       | 6                     | 10                  | 6             | 10  | 2,500         | 2,500 |                 |               |
|           | 3,500               | 2,295                  | 4,747                 | 150       | 6                     | 10                  | 6             | 10  | 2,500         | 2,500 |                 |               |
|           | 4,000               | 2,595                  | 5,347                 | 150       | 6                     | 6                   | 6             | 6   | 2,500         | 2,500 |                 |               |
|           | 4,500               | 2,845                  | 5,847                 | 150       | 6                     | 6                   | 6             | 6   | 2,500         | 2,500 |                 |               |
|           | 5,000               | 3,095                  | 6,347                 | 150       | 6                     | 6                   | 6             | 6   | 2,500         | 2,500 |                 |               |
| TF        | 3,210               | 2,155                  | 4,474                 | 950       | 6                     | 10                  | 6             | 10  | 2,500         | 2,500 |                 |               |
| TT        | 4,270               | 2,005                  | 5,554                 | 800       | 6                     | 6                   | 6             | 6   | 2,400         | 2,450 |                 |               |
|           | 4,710               | 2,145                  | 5,974                 | 940       | 6                     | 6                   | 6             | 6   | 2,300         | 2,350 |                 |               |
|           | 5,540               | 2,495                  | 6,799                 | 1,290     | 6                     | 4                   | 6             | 4   | 1,900         | 2,200 |                 |               |
|           | 5,990               | 2,645                  | 7,249                 | 1,440     | 6                     | 4                   | 6             | 4   | 1,400         | 2,100 |                 |               |
|           | 7,060               | 3,145                  | 8,298                 | 1,940     | 6                     | 4                   | 6             | 4   | 650           | 1,600 |                 |               |

\* Based on 1156 mm LBR

**Mast Chart CD30NXP**

| Mast Type | Maximum Fork Height | Maximum Lowered Height | Fully Extended Height | Free Lift | Rated Load Capacities |                     |               |     |               |       |                 |               |
|-----------|---------------------|------------------------|-----------------------|-----------|-----------------------|---------------------|---------------|-----|---------------|-------|-----------------|---------------|
|           |                     |                        |                       |           | With Load Backrest*   | With Load Backrest* | Tilt Angle    |     |               |       | Load Capacities |               |
|           |                     |                        |                       |           |                       |                     | Single Pneum. |     | Double Pneum. |       | Single Pneum.   | Double Pneum. |
|           |                     |                        |                       |           |                       |                     | FWD           | BWD | FWD           | BWD   | LC 500 mm       | LC 500 mm     |
|           |                     |                        |                       | deg       | deg                   | deg                 | deg           | kg  | kg            |       |                 |               |
| TL        | 3,000               | 2,045                  | 4,247                 | 150       | 6                     | 10                  | 6             | 10  | 3,000         | 3,000 |                 |               |
|           | 3,300               | 2,195                  | 4,547                 | 150       | 6                     | 10                  | 6             | 10  | 3,000         | 3,000 |                 |               |
|           | 3,500               | 2,295                  | 4,747                 | 150       | 6                     | 10                  | 6             | 10  | 3,000         | 3,000 |                 |               |
|           | 4,000               | 2,595                  | 5,347                 | 150       | 6                     | 6                   | 6             | 6   | 3,000         | 3,000 |                 |               |
|           | 4,500               | 2,845                  | 5,847                 | 150       | 6                     | 4                   | 6             | 4   | 2,950         | 3,000 |                 |               |
|           | 5,000               | 3,095                  | 6,347                 | 150       | 6                     | 4                   | 6             | 4   | 2,800         | 2,800 |                 |               |
| TF        | 3,210               | 2,155                  | 4,474                 | 950       | 6                     | 10                  | 6             | 10  | 3,000         | 3,000 |                 |               |
| TT        | 4,270               | 2,005                  | 5,554                 | 800       | 6                     | 6                   | 6             | 6   | 2,800         | 2,900 |                 |               |
|           | 4,710               | 2,145                  | 5,974                 | 940       | 6                     | 4                   | 6             | 4   | 2,650         | 2,800 |                 |               |
|           | 5,540               | 2,495                  | 6,799                 | 1,290     | 6                     | 4                   | 6             | 4   | 2,000         | 2,600 |                 |               |
|           | 5,990               | 2,645                  | 7,249                 | 1,440     | 6                     | 4                   | 6             | 4   | 1,500         | 2,450 |                 |               |
|           | 7,060               | 3,145                  | 8,298                 | 1,940     | 6                     | 4                   | 6             | 4   | 700           | 1,700 |                 |               |

\* Based on 1156 mm LBR

**Mast Chart CD33NXP**

| Mast Type | Maximum Fork Height | Maximum Lowered Height | Fully Extended Height | Free Lift | Rated Load Capacities |                     |               |     |               |       |                 |               |
|-----------|---------------------|------------------------|-----------------------|-----------|-----------------------|---------------------|---------------|-----|---------------|-------|-----------------|---------------|
|           |                     |                        |                       |           | With Load Backrest*   | With Load Backrest* | Tilt Angle    |     |               |       | Load Capacities |               |
|           |                     |                        |                       |           |                       |                     | Single Pneum. |     | Double Pneum. |       | Single Pneum.   | Double Pneum. |
|           |                     |                        |                       |           |                       |                     | FWD           | BWD | FWD           | BWD   | LC 500 mm       | LC 500 mm     |
|           |                     |                        |                       | deg       | deg                   | deg                 | deg           | kg  | kg            |       |                 |               |
| TL        | 3,000               | 2,045                  | 4,247                 | 150       | 6                     | 10                  | 6             | 10  | 3,300         | 3,300 |                 |               |
|           | 3,300               | 2,195                  | 4,547                 | 150       | 6                     | 10                  | 6             | 10  | 3,300         | 3,300 |                 |               |
|           | 3,500               | 2,295                  | 4,747                 | 150       | 6                     | 10                  | 6             | 10  | 3,300         | 3,300 |                 |               |
|           | 4,000               | 2,595                  | 5,347                 | 150       | 6                     | 6                   | 6             | 6   | 3,300         | 3,300 |                 |               |
|           | 4,500               | 2,845                  | 5,847                 | 150       | 6                     | 4                   | 6             | 4   | 3,220         | 3,220 |                 |               |
|           | 5,000               | 3,095                  | 6,347                 | 150       | 6                     | 4                   | 6             | 4   | 2,900         | 3,050 |                 |               |
| TF        | 3,210               | 2,155                  | 4,474                 | 950       | 6                     | 10                  | 6             | 10  | 3,300         | 3,300 |                 |               |
| TT        | 4,270               | 2,005                  | 5,554                 | 800       | 6                     | 6                   | 6             | 6   | 3,050         | 3,050 |                 |               |
|           | 4,710               | 2,145                  | 5,974                 | 940       | 6                     | 4                   | 6             | 4   | 2,900         | 2,950 |                 |               |
|           | 5,540               | 2,495                  | 6,799                 | 1,290     | 6                     | 4                   | 6             | 4   | 2,100         | 2,750 |                 |               |
|           | 5,990               | 2,645                  | 7,249                 | 1,440     | 6                     | 4                   | 6             | 4   | 1,600         | 2,600 |                 |               |
|           | 7,060               | 3,145                  | 8,298                 | 1,940     | 6                     | 4                   | 6             | 4   | 750           | 1,800 |                 |               |

\* Based on 1156 mm LBR

**Mast Chart CD35NXP**

| Mast Type | Maximum Fork Height | Maximum Lowered Height | Fully Extended Height | Free Lift | Rated Load Capacities |                     |               |     |               |       |                 |               |
|-----------|---------------------|------------------------|-----------------------|-----------|-----------------------|---------------------|---------------|-----|---------------|-------|-----------------|---------------|
|           |                     |                        |                       |           | With Load Backrest*   | With Load Backrest* | Tilt Angle    |     |               |       | Load Capacities |               |
|           |                     |                        |                       |           |                       |                     | Single Pneum. |     | Double Pneum. |       | Single Pneum.   | Double Pneum. |
|           |                     |                        |                       |           |                       |                     | FWD           | BWD | FWD           | BWD   | LC 500 mm       | LC 500 mm     |
|           |                     |                        |                       | deg       | deg                   | deg                 | deg           | kg  | kg            |       |                 |               |
| TL        | 3,000               | 2,045                  | 4,247                 | 150       | 6                     | 10                  | 6             | 10  | 3,500         | 3,500 |                 |               |
|           | 3,300               | 2,195                  | 4,547                 | 150       | 6                     | 10                  | 6             | 10  | 3,500         | 3,500 |                 |               |
|           | 3,500               | 2,295                  | 4,747                 | 150       | 6                     | 10                  | 6             | 10  | 3,500         | 3,500 |                 |               |
|           | 4,000               | 2,595                  | 5,347                 | 150       | 6                     | 6                   | 6             | 6   | 3,500         | 3,500 |                 |               |
|           | 4,500               | 2,845                  | 5,847                 | 150       | 6                     | 4                   | 6             | 4   | 3,360         | 3,350 |                 |               |
|           | 5,000               | 3,095                  | 6,347                 | 150       | 6                     | 4                   | 6             | 4   | 3,000         | 3,200 |                 |               |
| TF        | 3,210               | 2,155                  | 4,474                 | 950       | 6                     | 10                  | 6             | 10  | 3,500         | 3,500 |                 |               |
| TT        | 4,270               | 2,005                  | 5,554                 | 800       | 6                     | 6                   | 6             | 6   | 3,210         | 3,200 |                 |               |
|           | 4,710               | 2,145                  | 5,974                 | 940       | 6                     | 4                   | 6             | 4   | 3,100         | 3,100 |                 |               |
|           | 5,540               | 2,495                  | 6,799                 | 1,290     | 6                     | 4                   | 6             | 4   | 2,200         | 2,880 |                 |               |
|           | 5,990               | 2,645                  | 7,249                 | 1,440     | 6                     | 4                   | 6             | 4   | 1,700         | 2,750 |                 |               |
|           | 7,060               | 3,145                  | 8,298                 | 1,940     | 6                     | 6                   | 6             | 6   | 1,300         | 1,800 |                 |               |

\* Based on 1156 mm LBR

**Standard Features**

1. Yanmar 3.3-Litre, 4-Cylinder Inline Diesel
2. Single Speed Powershift Electrical
3. Power Drum Brakes
4. Dual Element Air Cleaner
5. Easy Side Panel Removal — No tools required
6. Large Entry Grip Bar
7. Anit-Skid Step Plate
8. Panoramic Mirror
9. Adjustable Steering Column
10. Steering Knob
11. LED Combination Lamps

**Optional Equipment**

1. Heavy Duty Radiator
2. Radiator Screen
3. High-Speed Fan
4. Pre-Cleaner
5. Vented Side Panel
6. Operator Sensing System
7. Donaldson Air Cleaner
8. Auto Shift Controller
9. Modular Cabin Styles
10. Rear Grab Bar with Horn
11. Quick Disconnect Hose Couplings
12. Heater
13. Fan

**Warning Device Options**

Audible or Visual Alerts

Safety considerations and dangers associated with audible travel alarms and lights include:

- Multiple alarms and/or lights can cause confusion.
- Workers ignore the alarms and/or lights after day-in, day-out exposure.
- Operator may transfer the responsibility for "looking out" to the pedestrians.
- Annoys operators and pedestrians.

**Other Options Available**

Contact factory for additional options.

*Dimensions and performance data given may vary due to manufacturing tolerances. Performance is based on an average-size vehicle and is affected by weight, condition of vehicle, how it is equipped and the conditions of the operating area. Products and specifications are subject to change without notice.*

**Crown Equipment Corporation**

New Bremen, Ohio 45869 USA

**Tel** 419-629-2311

**Fax** 419-629-3796

[crown.com](http://crown.com)

As Crown is continually improving its products, specifications are subject to change without notice.

Notice: Not all products and product features are available in all countries in which this literature is published.

Crown, the Crown logo, the colour beige and the Momentum symbol are trademarks of Crown Equipment Corporation in the United States and other countries.

Copyright 2019–2020 Crown Equipment Corporation  
SF20207-006 Rev. 12-20  
Printed in USA