

CROWN

# SP 3500 SP 4000 SERIES

**Specifications**  
Stockpicker

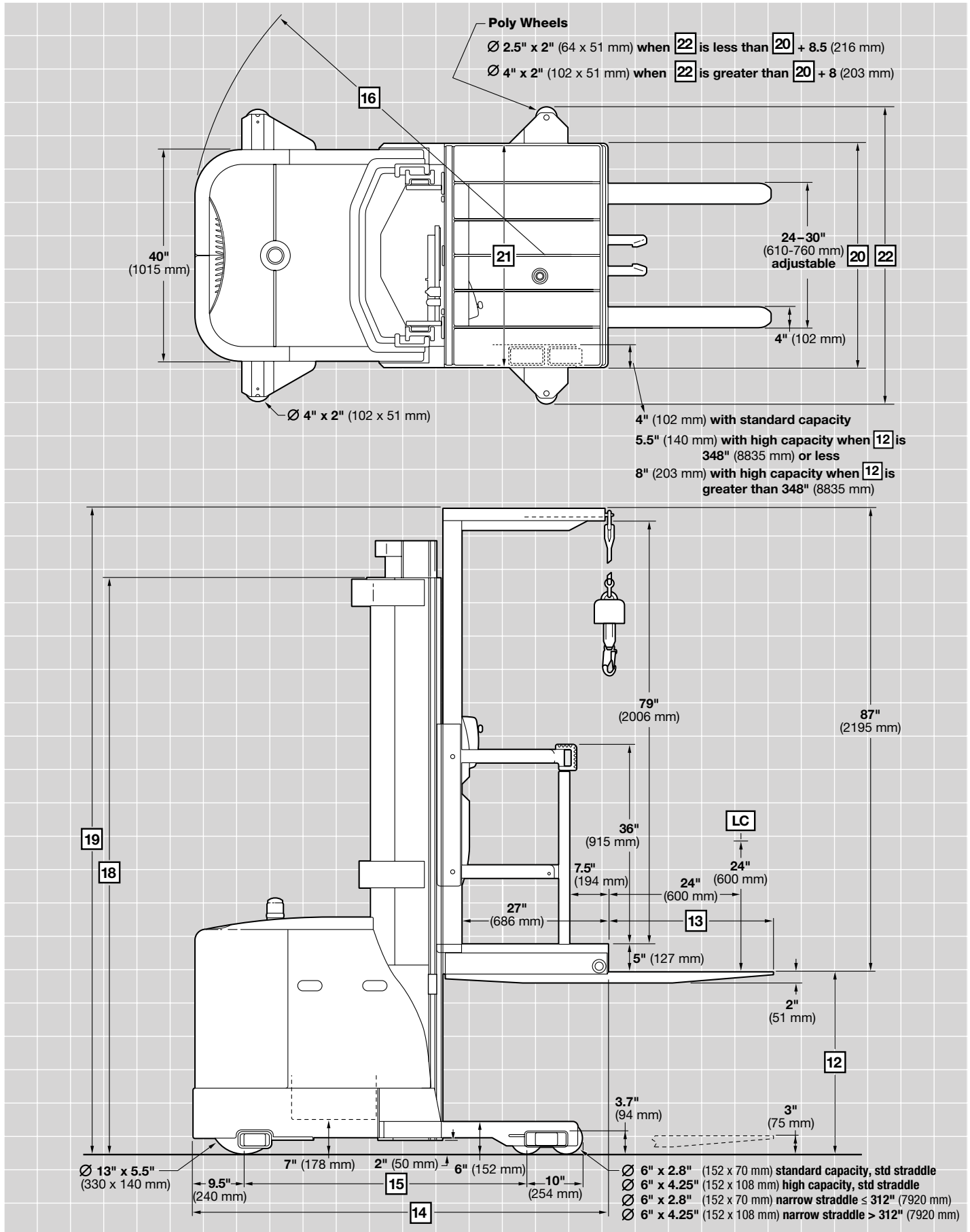



**SP 3500 Series**

Specifications

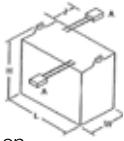
				Imperial	Metric
<b>General</b>	1	<b>Manufacturer</b>		<b>Crown Equipment Corporation</b>	
	2	<b>Model</b>		<b>SP 3500-30</b>	
	3	<b>Load Capacity*</b>	lb kg	See Charts	
	4	<b>Load Center</b>	Platform face to load CG in mm	24	600
	5	<b>Power</b>	Electric	24 Volts	
	6	<b>Operator Type</b>	Stand-up Rider	Stockpicker	
	7	<b>Tire Type</b>	Load/Drive	Poly / Poly	
<b>Performance</b>	8	<b>Speed Travel</b>	Empty/Loaded mph kmph	See Chart	
	9	<b>Speed Lift</b>	TL Empty fpm m/s	45 Std, 80 High Speed	0.225 Std, 0.405 High Speed
			TL Loaded fpm m/s	28 Std, 46 High Speed	0.140 Std, 0.230 High Speed
			TT Empty fpm m/s	40 Std, 71 High Speed	0.200 Std, 0.360 High Speed
			TT Loaded fpm m/s	26 Std, 43 High Speed	0.130 Std, 0.215 High Speed
	10	<b>Speed Lower</b>	TL Empty fpm m/s	40 Low, 80 High	0.200 Low, 0.405 High
			TL Loaded fpm m/s	38 Low, 75 High	0.190 Low, 0.380 High
			TT Empty fpm m/s	40 Low, 80 High	0.200 Low, 0.405 High
TT Loaded fpm m/s			38 Low, 75 High	0.190 Low, 0.380 High	
<b>Dimensions</b>	11	<b>Wheels (x = driven)</b>	Load/Drive	4 / 1x	
	12	<b>Lifting Height</b>	in mm	See Charts	
	13	<b>Forks</b>	Standard L x W x T in mm	36 x 4 x 2	915 x 102 x 51
			Optional Lengths in mm	30, 39, 42, 45, 48, 54, 60, 72, 84	760, 990, 1070, 1145, 1220, 1370, 1525, 1830, 2135
		<b>Battery Compartment</b>			
	14	<b>Head Length</b>	TL in mm	74.6	1895
			TT in mm	75.6	1920
15	<b>Wheel Base</b>	TL in mm	52	1320	
		TT in mm	51	1300	
16	<b>Turning Radius</b>	TL in mm	69	1755	
		TT in mm	68	1735	
<b>Battery</b>	 <p>-Width is measured on the sides of the battery with lifting hooks</p>	<b>Battery</b>	Type	Lead Acid "AA"	Lead Acid "B"
		Min Weight/Max Amp	lb amp	975 / 660	1520 / 1085
			kg amp	442 / 660	689 / 1085
		Max Battery Size L x W x H	in	31.75 x 13.12 x 23.25	36.25 x 14.25 x 31
			mm	806 x 333 x 590	921 x 362 x 787
		Connector Location/Length (J)	in	A / 22	A / 20
	Standard Connector		SB 175 Gray	SB 350 Red	

\*Contact factory. Capacity may be subject to derating, depending upon lifting height, load center and fork length.

**SP 4000 Series**

**Specifications**

				Imperial		Metric							
<b>General</b>	1	<b>Manufacturer</b>			<b>Crown Equipment Corporation</b>								
	2	<b>Model</b>			<b>SP 4000-30</b>								
	3	<b>Load Capacity*</b>	lb kg		See Charts								
	4	<b>Load Center</b>	Platform face to load CG	in mm	24		600						
	5	<b>Power</b>	Electric		36 Volts								
	6	<b>Operator Type</b>	Stand-up Rider		Stockpicker								
	7	<b>Tire Type</b>	Load/Drive		Poly / Poly								
<b>Performance</b>	8	<b>Speed Travel</b>	Empty/Loaded	mph kmph	See Chart								
	9	<b>Speed Lift</b>	TL	Empty	fpm m/s	100		0.508					
			TL	Loaded	fpm m/s	75		0.381					
			TT	Empty	fpm m/s	100		0.508					
			TT	Loaded	fpm m/s	75		0.381					
	10	<b>Speed Lower</b>	TL	Empty	fpm m/s	80		0.406					
			TL	Loaded	fpm m/s	80		0.406					
			TT	Empty	fpm m/s	80		0.406					
TT			Loaded	fpm m/s	80		0.406						
<b>Dimensions</b>	11	<b>Wheels (x = driven)</b>	Load/Drive		4 / 1x								
	12	<b>Lifting Height</b>	in mm		See Charts								
	13	<b>Forks</b>	Standard	L x W x T	in mm	36 x 4 x 2		915 x 102 x 51					
			Optional Lengths	in mm		30, 39, 42, 45, 48, 54, 60, 72, 84		760, 990, 1070, 1145, 1220, 1370, 1525, 1830, 2135					
		<b>Battery Compartment</b>			B		C		D		E		
	14	<b>Head Length</b>	TL	in mm		74.6	1895	76.9	1953	78.5	1994	81.1	2060
			TT	in mm		75.6	1920	77.9	1979	79.5	2019	82.1	2085
15	<b>Wheel Base</b>	TL	in mm		52	1321	54	1378	56	1419	59	1486	
		TT	in mm		51	1302	53	1359	55	1400	58	1467	
16	<b>Turning Radius</b>	TL	in mm		69	1753	71	1803	73	1854	75.5	1918	
		TT	in mm		68	1727	70	1778	72	1829	74.5	1892	
<b>Battery</b>	17	<b>Battery</b>		-Width is measured on the sides of the battery with lifting hooks	Type	Lead Acid "B"	Lead Acid "C"	Lead Acid "D"	Lead Acid "E"				
					Min Weight/Max Amp	lb amp	1700 / 775	2000 / 930	2280 / 1085	2600 / 1240			
						kg amp	770 / 775	907 / 930	1034 / 1085	1179 / 1240			
					Max Battery Size L x W x H	in	38.44 x 14.25	38.44 x 16.25	38.69 x 18.19	38.69 x 20.75			
						mm	x 31	x 31	x 31	x 31			
					Connector Location/Length (J)	in	A / 20						
Standard Connector	SB 350 Gray												

\*Contact factory. Capacity may be subject to derating, depending upon lifting height, load center and fork length.

# SP 3500/4000 Series

## Specifications

### Standard Straddle – TL Mast

12	<b>Lifting Height</b>	in mm	136	3450	148	3755	172	4365	194	4925	214	5435
	<b>Standard Capacity</b>	lb t	3000	1.3	3000	1.3	3000	1.3	3000	1.3	3000	1.3
	<b>High Capacity</b>	lb t	na	na	na	na	na	na	na	na	na	na
	<b>Free Lift</b>	in mm	3	75	6	155	6	155	6	155	6	155
18	<b>Collapsed Height</b>	in mm	89.5	2270	95	2410	107	2715	119	3020	131	3325
19	<b>Extended Height</b>	in mm	223	5670	235	5975	259	6585	281	7145	301	7650
20	<b>Straddle Width</b>	in mm	42	1065	42	1065	42	1065	42	1065	42	1065
21	<b>Operator Compartment Width</b>	in mm	42	1065	42	1065	42	1065	42	1065	42	1065
22	<b>Aisle Guide Wheel Range †</b>	in mm	45.50 to 65.25	1156 to 1658	45.50 to 65.25	1156 to 1658	45.50 to 65.25	1156 to 1658	45.50 to 65.25	1156 to 1658	45.50 to 65.25	1156 to 1658
	<b>Truck Weight Without Battery</b>	lb kg	5130	2332	5189	2358	5319	2418	5607	2548	5737	2608

### Standard Straddle – TT Mast

12	<b>Lifting Height</b>	in mm	195	4950	210	5330	240	6095	276	7010
	<b>Standard Capacity</b>	lb t	3000	1.3	3000	1.3	3000	1.3	2000	0.9
	<b>High Capacity †††</b>	lb t	na	na	na	na	na	na	2500	1.1
	<b>Free Lift</b>	in mm	3	75	8	215	20	520	32	825
18	<b>Collapsed Height</b>	in mm	89.5	2270	95	2410	107	2715	119	3025
19	<b>Extended Height</b>	in mm	283	7175	298	7555	328	8320	364	9230
20	<b>Straddle Width</b>	in mm	42	1065	42	1065	42††	1065	48	1220
21	<b>Operator Compartment Width</b>	in mm	42	1065	42	1065	42	1065	48	1220
22	<b>Aisle Guide Wheel Range †</b>	in mm	45.50 to 65.25	1156 to 1658	45.50 to 65.25	1156 to 1658	45.50 to 65.25	1156 to 1658	48.75 to 71.25	1240 to 1810
	<b>Truck Weight Without Battery</b>	lb kg	5704	2592	5789	2631	5975	2716	6453	2933

### Standard Straddle – TT Mast

12	<b>Lifting Height</b>	in mm	294	7465	312	7920	330	8380	348	8835	366	9295	384	9750	402	10210
	<b>Standard Capacity</b>	lb t	1750	0.7	1500	0.6	na	na	na	na	na	na	na	na	na	na
	<b>High Capacity †††</b>	lb t	2350	1.1	2200	1.0	2050	0.9	1900	0.9	1750	0.7	1750	0.7	1750	0.7
	<b>Free Lift</b>	in mm	38	980	44	1130	56	1435	62	1590	68	1740	74	1890	84	2140
18	<b>Collapsed Height</b>	in mm	125	3175	131	3325	143	3630	149	3780	155	3935	161	4085	171	4340
19	<b>Extended Height</b>	in mm	382	9690	400	10145	418	10605	436	11060	454	11520	472	11970	490	12435
20	<b>Straddle Width</b>	in mm	54	1370	54	1370	56	1420	60	1525	60	1525	64	1625	64	1625
21	<b>Operator Compartment Width</b>	in mm	54	1370	54	1370	54	1370	60	1525	60	1525	64	1625	64	1625
22	<b>Aisle Guide Wheel Range †</b>	in mm	54.75 to 77.25	1390 to 1962	54.75 to 77.25	1390 to 1962	56.75 to 79.25	1440 to 2013	60.75 to 83.25	1543 to 2115	60.75 to 83.25	1543 to 2115	64.75 to 87.25	1644 to 2216	64.75 to 87.25	1644 to 2216
	<b>Truck Weight Without Battery</b>	lb kg	6636	3016	6728	3058	6924	3147	7094	3224	7524	3420	7750	3515	7905	3585

### Narrow Straddle – TT Mast ††††

12	<b>Lifting Height</b>	in mm	294	7465	312	7920	330	8380	348	8835	366	9295
	<b>Standard Capacity</b>	lb t	1200	0.5	1000	0.4	1000	0.4	900	0.4	900	0.4
	<b>Free Lift</b>	in mm	38	980	44	1130	56	1435	62	1590	68	1740
18	<b>Collapsed Height</b>	in mm	125	3175	131	3325	143	3630	149	3780	155	3935
19	<b>Extended Height</b>	in mm	382	9690	400	10145	418	10605	436	11060	454	11520
20	<b>Straddle Width</b>	in mm	48	1220	48	1220	52	1320	56	1420	56	1420
21	<b>Operator Compartment Width</b>	in mm	48	1220	48	1220	48	1220	54	1370	54	1370
22	<b>Aisle Guide Wheel Range †</b>	in mm	48.75 to 71.25	1240 to 1810	48.75 to 71.25	1240 to 1810	48.75 to 71.25	1240 to 1810	56.75 to 79.25	1440 to 2013	56.75 to 79.25	1440 to 2013
	<b>Truck Weight Without Battery</b>	lb kg	6636	3016	6728	3058	6924	3147	7424	3367	8014	3635

† In 0.25" (6 mm) increments

†† 48" (1220 mm) straddle width on "AA" battery only

††† 36V is high capacity when lift height is greater than 240" (6095 mm) unless narrow straddle is selected

†††† 3/8" (10 mm) skid bar clearance (LH 294" to 330" [7465 to 8380 mm], narrow straddle)

Extended skid bars added (LH > 330" [8380 mm], narrow straddle)

## SP 3500/4000 Series

## Specifications

Lift Height (inches/ mm)	Steered Wheel < 10° <sup>(1)</sup>		
	Power Unit First (PUF) <sup>(2)</sup> Travel Speed (mph/kmph) Empty/Loaded		
	Standard Capacity "AA" Battery	Standard Capacity <sup>(3)</sup>	High Capacity
0 - 24	6.5	7.5	7.5
0 - 610	10.4	12.0	12.0
24 - 64	6.5 - 5.5	7.5 - 6.0	7.5 - 6.5
610 - 1625	10.4 - 8.8	12.0 - 9.6	12.0 - 10.4
64 - 120	5.5 - 3.3	6.0 - 3.8	6.5 - 4.5
1625 - 3048	8.8 - 5.3	9.6 - 6.1	10.4 - 7.2
120 - 152	3.3 - 2.1	3.8 - 2.7	4.5 - 3.4
3048 - 3861	5.3 - 3.3	6.1 - 4.3	7.2 - 5.4
152 - 175	2.1 - 1.2	2.7 - 2.0	3.4 - 2.6
3861 - 4445	3.3 - 1.9	4.3 - 3.2	5.4 - 4.1
175 - 192	1.2	2.0 - 1.5	2.6 - 2.2
4445 - 4877	1.9	3.2 - 2.4	4.1 - 3.5
192 - 216	1.2	1.5	2.2 - 1.5
4877 - 5486	1.9	2.4	3.5 - 2.4
216 - max	1.2	1.5	1.5
5486 - max	1.9	2.4	2.4

<sup>(1)</sup> Top travel speed is reduced to 80% at a 10° steering angle, beyond 10° travel speeds gradually reduce down to 50% of top travel speed. Steering angle is automatically limited to within 10° straight travel as indicated below:

- Standard Capacity "AA" Battery above 176" (4470 mm)
- Standard Capacity above 192" (4877 mm)
- High Capacity above 216" (5486 mm)

<sup>(2)</sup> From 0-60 inches (0-1524 mm), travel speeds in the Forks First (FF) direction of travel are approximately 0.5 mph (0.8 km/h) less than travel speeds in the Power Unit First (PUF) direction.

<sup>(3)</sup> Standard straddle and narrow straddle models

## SP 3500/4000 Series

## Technical Information

### Standard Equipment

1. Crown's Access 1 2 3<sup>®</sup> Comprehensive System Control
2. Crown's AC traction control system
3. 24-volt or 36-volt electrical system
4. Electronic steering
5. Linear Height Speed Control
6. Variable Lift/Lower (36V only)
7. Regenerative Lower (36V only)
8. Programmable lift/lower cut-outs
9. Intelligent Braking with low-profile brake pedal

10. Crown Display
  - Battery discharge indicator with lift interrupt
  - Hour meters/travel distance/stop watch
  - PIN code access capable
  - Access 1 2 3 diagnostics
  - P1, P2, P3 Performance
  - Standard steer tire direction indicator (non wire-guided trucks)
  - Enhanced steer tire direction indicator (wire-guided trucks)
11. Soft urethane twist grip with "cam grip"
12. 10° angled steer wheel with soft feel spinner
13. Storage compartment
14. Premium platform cushion

15. Clear visibility platform window
16. Wire mesh screen
17. Key switch
18. Horn
19. LED flashing light
20. Hinged side gates with power disconnect
21. 175 amp battery connector for "AA" battery box
22. 350 amp for "B", "C", "D", and "E" battery boxes
23. 2" (51 mm) diameter battery compartment rollers
24. Top battery access for service
25. Removable steel battery side covers
26. Adjustable battery retainer

27. Hinged, lift off steel power unit doors
28. Corrosion conditioning
29. Emergency power cut-out
30. Retractable tether and body harness
31. Pallet clamp
32. InfoPoint<sup>®</sup> Quick Reference Guide and Maps
33. Color-coded wiring
34. 6" (152 mm) diameter tandem load wheels

## SP 3500/4000 Series

## Technical Information

### Optional Equipment

1. High-speed travel
2. High-speed lift
3. High capacity
4. Crown wire guidance (broadband technology) operates on all frequencies ranging from 5.2 through 10 kHz without changing components
5. End of Aisle Control System (wire or rail guidance required)
6. Aisle guide wheels for rail guidance
7. Lift motor brush wear and overtemp indicator (24V only)
8. Battery retainer interlock switch
9. V-Force® Lithium-Ion Ready
10. Electric pallet clamp
11. LED work lights, LED dome light and two-speed fan
12. Additional operator fan
13. Spotlights - LED or Halogen
14. Floor Spotlight - Blue
15. Programmable lift/lower cutouts with over-rides.
16. Zone select key switch
17. 48" (1220 mm), 54" (1370 mm), and 60" (1525 mm) wide operator platforms
18. Freezer conditioning (Includes corrosion conditioning, ribbed floor mat, and wire mesh windshield)
19. UL EE Rating
20. Glass windshield
21. Load wheel and drive tire compounds
22. 30" (762 mm) lanyard boom
23. InfoLink® Ready
24. Positive / negative accessory cable
25. Special paint
26. Work Assist® Accessories
  - Storage Bin
  - Clip pad and hook
  - Plate
  - Pocket
27. Fire extinguisher

### Operator Platform

The operator area is designed for maximum visibility and stability for increased operator confidence and comfort.

The operator platform features a large window (1088 sq in) (701930 mm<sup>2</sup>) for excellent visibility. A Crown-designed clear-visibility mast affords the platform window one forward and two peripheral windows for maximum visibility, even when the platform is lowered.

The clear-visibility mast, with full free lift, extends the platform window above the mast channels for unobstructed visibility when raised.

A low-profile power unit, low placement of the lower cross brace and an outer C-channel rail assembly also contribute to excellent visibility.

A soft urethane twist grip is solidly mounted to the truck console to provide excellent stability for the operator during travel, plugging and braking. Controls for lift/lower, horn and emergency disconnect are conveniently located for efficient operation and minimal operator fatigue. The steering wheel is angled at 10° and recessed to maximize the work area and reduce steer effort. The steering wheel and spinner knob are covered with soft urethane to reduce grip force and insulate against vibration. Control location keeps the operator's posture neutral at all times.

The platform cushion, made of a microcellular composition, absorbs shock and vibration.

The brake pedal has a low-profile design and when engaged is flush with the platform cushion for maximum comfort. Heavy-duty side gates, with two horizontal and one vertical support rails, communicate security to the operator. For additional safety, cut-out switches disengage truck operation when side gates are raised.

Two work lights, two dome lights and a two-speed fan are optional. "Power-on" key prevents unauthorized operation of the truck. The Access 1 2 3® Display Panel provides concise, clear feedback for the operator during truck operation.

### Crown's Access 1 2 3®...

The Comprehensive Access 1 2 3 System Control is a modular based communications and control system. It monitors all on-board sensors, makes decisions based on the sensor readings, and subsequently, controls all system movements safely and smoothly. All five modules are in constant communications with each other via a CAN (Control Area Network) bus so that real information is accessible to the system at all times.

- Interactive Display Module
- Traction Control Module
- Vehicle Control Module
- Steering Control Module
- Guidance Control Module

### Crown Drive System

Crown has applied the latest generation AC drive system, enhanced with Access 1 2 3 technology. A Crown-manufactured drive unit uses spiral bevel and helical gears from motor to drive wheel axle.

Fixed, mounted drive motor does not rotate minimizing wear on electrical cables. Drive tire changing is simplified with this drive unit.

Crown's AC Drive system dramatically improves travel speeds, acceleration and deceleration, thus increasing productivity.

The standard linear speed control provides smooth travel speed transition as lift heights change and increases productivity.

### Travel System

Truck performance specifications (maximum travel speed, coast, plugging, acceleration, travel speed at height, and low speed lowering) are adjustable using Access 1 2 3. This enables customizing truck performance to meet specific application or operator requirements.

Crown's InfoPoint system offers evolutionary refinement for service simplicity. The InfoPoint Quick Reference Guide, on-truck component maps and information nuggets located throughout the truck allow technicians to troubleshoot without schematics, wiring diagrams, or service manuals for more than 95 percent of repairs.

The InfoPoint Quick Reference Guide provides code definition and overall component ID so the technician knows what it is, where it is, and what it does (Three W's). InfoPoint ensures faster, simpler, and higher quality service.

### Intelligent Steering

Standard on the SP 3500/SP 4000 Series is electronic steering that is microprocessor based.

Crown's intelligent steering feature slows the truck automatically when the steer wheel is turned beyond 10°. Access 1 2 3 monitors the height of the operator platform, truck speed and steer wheel position.

Steering wheel rotation provides smooth, operator feedback. Steer effort is minimal, lock to lock revolutions is 4.5 turns. Drive wheel rotates a full 180° for maximum maneuverability. Auto centering drive tire for trucks equipped with rail guidance. Steering is connected to the Control System for full diagnostics and operator interface.

## SP 3500/4000 Series

## Technical Information

### Intelligent Braking

Crown's patented Intelligent Braking combines motor braking with optimum amounts of friction braking (three varying levels of force). The appropriate level of braking is applied dependent upon platform height, direction of travel, and truck weight. Braking force is automatically reduced as height increases and speed decreases. Optimum braking for the right elevation gives operators more confidence and better control, while eliminating abrupt stops and reducing platform sway. Brake lining life can be expected to last up to twice as long before replacement is necessary.

Braking can also be accomplished by proportional plugging, which permits the operator to control the rate of deceleration when extended stopping distance is preferred.

### Simplified Hydraulics

Heavy-duty series wound pump motors and gear pumps are assembled into an integral unit. Variable lift and lower is standard on SP 4000. High speed lift is optional on SP 3500.

Two-speed lowering (high/low) with soft start is standard on SP 3500 models. Low speed lowering is adjustable with the use of the Access 1 2 3 display. Soft-start lowering feature reduces the harshness at the beginning

and end of the lowering cycle. The softer start is accomplished by controlling how quickly the proportional valve is opened or closed. Valve actuation is controlled by a driver in the steering control module.

Maximum lowering speed is regulated by a pressure compensating flow control valve. Velocity fuses are used in all cylinders to stop lowering should lowering speed exceed a preset value due to a line rupture. A hydraulic accumulator is used to cushion raise and lower functions on the SP 3500. Oil reservoir is designed with a 100 mesh screen at the fill location, a suction strainer, spin-on type 10 micron return line filter and a magnetic drain plug.

### The Crown Mast Assembly

High visibility two- and three-stage masts feature nested rail design with lift cylinders positioned behind mast rails. Three-stage mast has a low center position cylinder for free lift. Routing of hosing and cables optimizes visibility through mast. Built-in sensors detect chain slack and shut down primary lower function. Exclusive spring-loaded staging bumpers virtually eliminate platform impact as platform stages. Negative rail drop allows shimming of mast rollers without major disassembly.

### Stronger Low Profile Power Unit

Power unit is fabricated from heavy-gauge steel. Lower skirt is 0.75" (19 mm) steel that runs 9" (228 mm) high for component protection. Rugged steel doors suspended on heavy-duty pin hinges cover power unit componentry. Doors swing wide for open access. Doors can also be lifted off for unrestricted service access. Door bolts have exclusive convex design that mates with concave door holes for fast reinstallation of door bolts. Battery side covers are all steel. An optional battery retainer interlock switch is available. Top battery access is available by lifting cover. Cover has integral support post.

### Wheels and Tires

Polyurethane drive tire, 13" (330 mm) diameter x 5.5" (140 mm) wide x 8" (203 mm) hub diameter. Tandem load wheels are 6" (152 mm) diameter polyurethane x 2.8" (70 mm) wide (4.25" (108 mm) wide for high capacity trucks). Optional polyurethane aisle guide wheels are 2" (51 mm) wide with a 4" (102 mm) or 2.5" (64 mm) diameter.

### Forks

2" (51 mm) thick x 4" (102 mm) wide forged steel. Fork spread (adjustable) 24" (610 mm) to 30" (760 mm). Standard length is 36" (915mm). Optional lengths available.

### Pallet Clamp

Standard equipment includes a foot-applied, hand-released pallet clamp designed for use with pallets having center stringers.

### Warning Device Options

Audible or Visual Alerts

Safety considerations and dangers associated with audible travel alarms and lights include:

- Multiple alarms and/or lights can cause confusion.
- Workers ignore the alarms and/or lights after day-in and day-out exposure.
- Operator may transfer the responsibility for "looking out" to the pedestrians.
- Annoys operators and pedestrians.

### Other Options Available

Contact factory for additional options.

*Dimensions and performance data given may vary due to manufacturing tolerances. Performance is based on an average size vehicle and is affected by weight, condition of truck, how it is equipped and the conditions of the operating area. Crown products and specifications are subject to change without notice.*



### Crown Equipment Corporation

New Bremen, Ohio 45869 USA  
Tel 419-629-2311  
Fax 419-629-3796  
crown.com

**You can count on Crown to build lift trucks designed for safe operation, but that's only part of the safety equation. Crown encourages safe operating practices through ongoing operator training, safety-focused supervision, maintenance and a safe working environment. Go to crown.com and view our safety section to learn more.**

Because Crown is continually improving its products, specifications are subject to change without notice.

Crown, the Crown logo, the color beige, the Momentum symbol, Work Assist, Access 1 2 3, InfoLink, V-Force and InfoPoint are trademarks of Crown Equipment Corporation in the United States and other countries.

Copyright 2005-2020 Crown Equipment Corporation  
SF14832 Rev. 05-20  
Printed in U.S.A.