



## S160 Series

**Powerful**  
**Versatile**  
**Maneuverable**

The S160 Series  
16,000 lb rough terrain forklift

Four wheel drive

Four wheel steer

 **SELICK**

## Standard specifications

Explore the versatility of the rugged heavy-duty S160 Series forklift. This addition to the popular S Series forklift line provides 16,000 lbs of lifting capacity @ 24" load centre. Meets or exceeds ANSI B56.6 ROPS/FOPS standard.

## Engine

DieselMax 444 low noise, low emission, turbocharged, intercooled, four-cylinder, 114 hp, direct injection diesel engine with fuel/water separator with hand primer, dual element air filter, maintenance free pre-cleaner & vertical exhaust.

## Transmission

Six-speed fully automatic powershift transmission

## Axles

Trunnion mounted planetary axles. Internal hydraulic disc brakes, limited slip front differential provides increased traction. Integral steer cylinders.

Frame leveling - 5° from centre

## Brake system

Enclosed multi-disc, oil-immersed service brakes with independent parking brake, spring applied, hydraulically released, axle mounted.

## Steering

4 wheel steering with hydraulic power assist.

## Instruments

Full instrument package includes hour meter, water in fuel gauge and air restriction monitor.

## Mast assemblies

SEE-THRU® all-roller mast design. Internal hose routing  
84" shaft carriage

## Optional equipment

- Turn signals
- Block heater
- Cab with lockable doors & tinted windows
- Full range of lift heights available
- Variety of forks available for any application
- AM/FM MP3 player
- Air conditioning
- Outside rear-view mirrors
- Integral sideshift
- Integral fork positioner w/ sideshift

# S160 rough terrain forklift

Lift capacity of 16,000 lbs @ 24" load centre

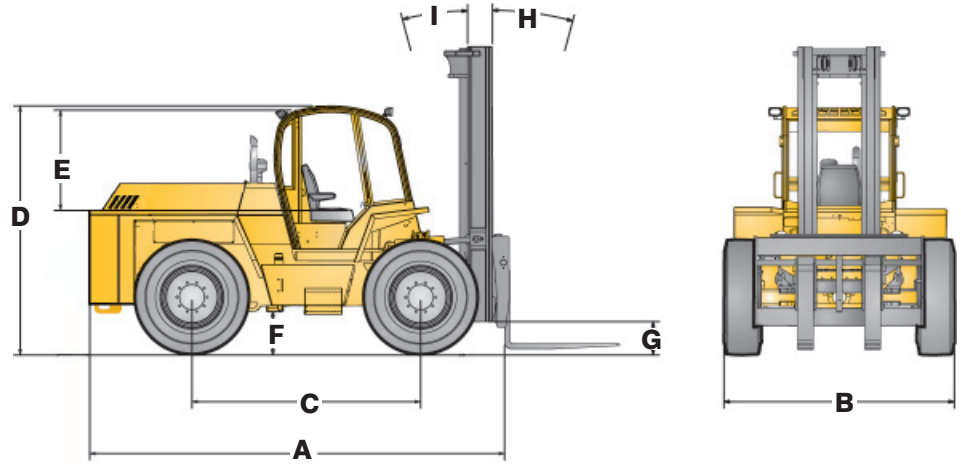

Model	Ref	S160
Lift capacities @ 24 inch load centre		16 000 lbs
Overall length	A	188"/4 775 mm
Overall width	B	100"/2 540 mm
Wheelbase	C	100"/2 540 mm
Height to top of overhead guard	D	106"/2 692 mm
Distance from seat to overhead guard	E	43"/1 092 mm
Outside turning radius		150"/3 810 mm
Frame underclearance	F	21"/533 mm
Mast underclearance	G	12"/305 mm
Carriage sideshift		6"/152 mm
Mast tilt - forward	H	15°
Mast tilt - rearward	I	12°
Axle(s)		Dana 213 Series
Travel speed (standard)		16 mph
Gradeability		25%
Tire size type & size		Front/Rear (pneumatic) 15.5 x 25 - 16 ply L3
Electrical System		Alternator - 95A; Battery 1 000 CCA (12 volt system)
Engine model		Dieselmax 444 Series intercooled turbocharged
Cylinders		4
Engine output (gross power)		114 hp @ 2 200 rpm
Peak torque		325 ft-lbs @ 1 300 rpm
Transmission manufacturer & type		Dana T20000 Automatic Powershift

*Because of our constant dedication to product improvement, all specifications are subject to change without notice.*

## SELICK

Sellick Equipment Limited  
P.O. Box 1000/358 Erie Street North  
Harrow, Ontario, Canada • N0R 1G0  
519-738-2255 • sellick@mnsi.net  
www.sellickequipment.com

