

CROWN

WAV 60 SERIES

Specifications

Work Assist Vehicle®



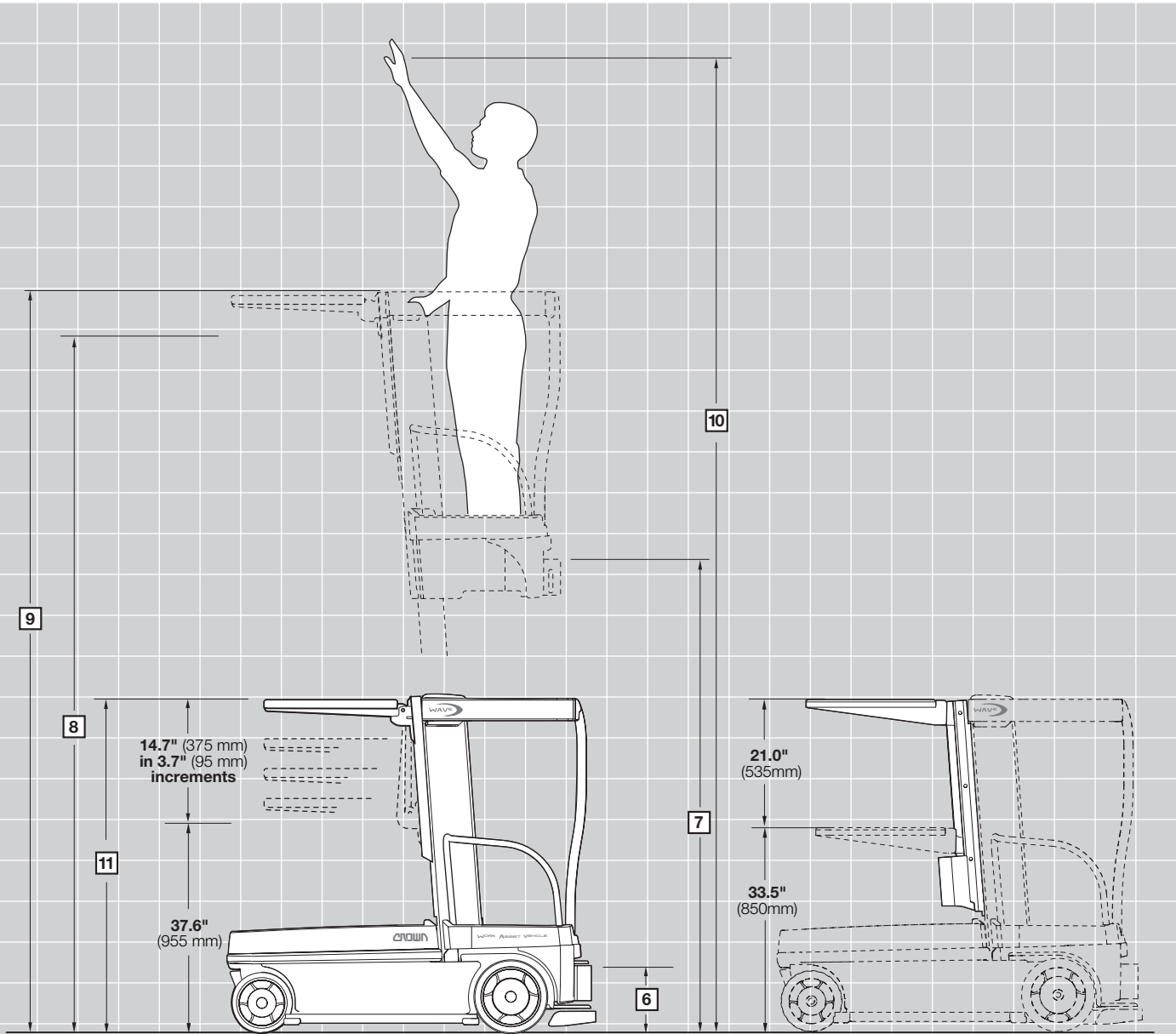

Standard Load Tray Shown

Optional Power Load Tray Shown

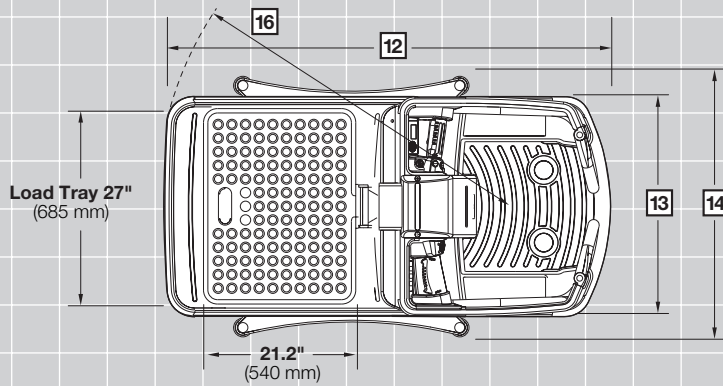

WAV 60 Series

Specifications

			Imperial	Metric	
General Information	1	Manufacturer	Crown Equipment Corporation		
	2	Model	WAV 60-118		
	3	Power	24 volts		
	4	Vehicle Capacities	Operator Compartment	lb kg	300 135
			Load Tray	lb kg	200 90
			Load Deck	lb kg	250 115
5	Vehicle Weight	With Battery	lb kg	1420 645	
6	Platform Step Height		in mm	12 305	
Dimensions	7	Platform Lift Height		in mm	118 2995
	8	Standard Load Tray*	Platform fully lowered	in mm	52.25 1325
			Platform fully raised	in mm	158.25 4020
		Power Load Tray	Lift Speed (no load)	in sec m sec	5.4 0.135
			Lift Speed (200 lb / 90.71 kg)	in sec m sec	5 0.130
			Platform fully lowered	in mm	54.0 1375
			Platform fully raised	in mm	160.0 4065
	9	Overall Extended Height		in mm	160.5 4075
	10	Work Height		in mm	195 5000
	11	Overall Collapsed Height		in mm	54.5 1385
	12	Vehicle Length		in mm	60 1525
	13	Vehicle Width		in mm	29.5 750
	14	Vehicle Width	With Rail Guide Rollers	in mm	35 890
			Rail Guide Wheel Height (Top)	in mm	2.5 65
			Rail Guide Wheel Diameter	in mm	2.5 65
Rail Guide Wheel Thickness			in mm	1 25	
15	Rear Drive Wheels (d x w)	Poly	in mm	(2) 12 x 2.5 (2) 305 x 65 wide	
	Front Caster Wheels (d x w)	Poly	in mm	(2) 10 x 2.5 (2) 255 x 65 wide	
Performance	16	Minimum Turning Radius		in mm	47.5 1205
	17	Lift Speeds		fpm m/s	60 0.30
	18	Lower Speeds		fpm m/s	45 0.25
	19	Service Brakes			Regenerative
	20	Parking Brake			Electric Released/Spring Applied
	21	Grade Clearance		%	15%
	22	Travel Speeds			See Chart Below
Battery	23	Batteries	Wet	Ah	180
			Wet	Ah	219
			Maintenance free	Ah	200
	24	Charger	Standard	Amp	30

*Load tray is 2.25" (57 mm) below top of restraint rail on WAV 60-118

Top Travel Speeds mph (km/h)

Forward		WAV 60-118	
Platform Ht	Gate Condition	mph	km/h
Below 20" (510 mm)	Open	5.0	8.0
Below 20" (510 mm)	Closed	3.0	4.8
20" to 84" (2135 mm)	Open	0	0
20" to 84" (2135 mm)	Closed	2.0	3.2
Above 84" (2135 mm)	Open	0	0
Above 84" (2135 mm)	Closed	1.0	1.6

Top Travel Speeds mph (km/h)

Reverse		WAV 60-118	
Platform Ht	Gate Condition	mph	km/h
Below 20" (510 mm)	Open or Closed	2.0	3.2
20" to 84" (2135 mm)	Open	0	0
20" to 84" (2135 mm)	Closed	2.0	3.2
Above 84" (2135 mm)	Open	0	0
Above 84" (2135 mm)	Closed	1.0	1.6

Intelligent Control

A system controller manages vehicle travel, steering, braking, lift/lower and the display. The vehicle operates quietly and efficiently, extending battery charge. Vehicle performance is infinitely variable for excellent control and maneuverability.

Steering

The Wave® vehicle has a zero inside turn radius. A unique steer control interfaces with the operator. The system controller and dual drive units provide exceptional vehicle turning ability.

Braking

Regenerative braking is automatic when throttle speed is reduced or when the operator removes a hand or foot from the controls. A parking brake is automatically set one-half second after travel has stopped.

Serviceability

Modular design for servicing keeps the vehicle cost effective. Component access is simple. Charger operation is intuitive, with the built-in automatic start/stop. Maintenance-free batteries can be specified to eliminate battery watering. Crown's Access 1 2 3® technology provides optimum performance and control by offering a communication interface for both operators and technicians, intelligent coordination of lift truck systems and simplified service with advanced diagnostics.

The Crown display is used for easy troubleshooting, accessing event history and to set performance features.

Three modes of performance can be selected to accommodate operator experience or application requirements.

Durability

Cast steer and load wheels for improved durability. Steel Front and Rear bumpers offer defense to the truck if an impact would happen. Steel service and side panels. Service Panel Switch to prevent travel when panel is open.

Standard Equipment

1. Crown's Access 1 2 3® Comprehensive System Control
2. Designed to UL 583 type "E"
3. Multiple Hour Meters
 - Travel Hours
 - Raise Hours
 - Idle Hours
 - Configurable Planned Maintenance Timer
4. 24 volt system
5. Transistor system controller
6. 180 amp hour wet-cell batteries
7. Work Assist® Storage Tray
8. 30 amp auto start/stop charger (85-265 vac)
9. 118" (2995 mm) Platform Height
10. On/off keyswitch
11. Horn
12. Operator storage compartments
13. Alphanumeric display and related icons are used to prompt operator through Crown's safety features. For example... grab controls, depress pedals, close gates, etc.
14. Battery Charging Display on service panel indicating:
 - Abnormal Charge
 - Charging
 - Charge Complete
15. Travel speed switch, (rabbit/turtle switch)
16. Power disconnect button located on platform and service panel.
17. Regenerative service brake
18. Electromagnetic park brakes
19. Gate position interlocks

20. Gate Alarms
21. Raise and lower control on platform and on the service panel, (floor level)
22. Programmable security power up
23. Auto power shutdown, (0 - 90 minute range)
24. Black wheels
25. AC Drive Motors
26. AC Controls
27. InfoPoint® System
28. Front and Side Steel Bumpers

Optional Equipment

1. 200 amp hour batteries, (maintenance free)
2. 219 amp hour wet batteries
3. Retractable cord reel
4. Mast storage pockets
5. Mast Storage Bins
6. Rail guide rollers
7. Utility hooks 25 lb (12 kg) capacity per hook
8. Storage Tray work lights
9. Clip Pad
10. Accessory Mount
11. Front and Side Steel Bumpers with Rubber Over Mold
12. Power Load Tray
13. Positive/Negative Accessory Cable
14. Travel Alarms
15. Keyless on/off toggle
16. Flashing Lights
17. InfoLink® Standard and Advantage Plans

Operator Interface

The Wave Work Assist Vehicle® has a comfortable work station for the operator. The floorboard is suspended to absorb shock and vibration, reducing fatigue. Foot and hand interlocks position the operator for good control and safety. Gate interlocks determine open or closed gate conditions and adjust vehicle performance.

Vehicle travel speed is reduced as the operator platform elevates. Maximum travel speeds can be reduced to meet the application requirements. An auto power shutdown can be programmed from 0 - 90 minutes to assist in preventing or unauthorized use.

Other Options

1. Program selective forward, reverse, lift and lower alarms
2. Front and rear flashing lights

Safety considerations and dangers associated with audible travel alarms and flashing lights include:

- Multiple alarms and/or lights can cause confusion.
- Workers ignore the alarms and/or lights after day-in and day-out exposure.
- Operator may transfer the responsibility for "looking out" to the pedestrians.
- Annoys operators and pedestrians.

Other Options Available

Contact your local Crown dealer.

Dimensions and performance data given may vary due to manufacturing tolerances. Performance is based on an average size vehicle and is affected by weight, condition of truck, how it is equipped and the conditions of the operating area. Crown products and specifications are subject to change without notice.

**Crown Equipment Corporation**

New Bremen, Ohio 45869 USA
Tel 419-629-2311
Fax 419-629-3796
 crown.com

You can count on Crown to build lift trucks designed for safe operation, but that's only part of the safety equation. Crown encourages safe operating practices through ongoing operator training, safety-focused supervision, maintenance and a safe working environment. Go to crown.com and view our safety section to learn more.

Because Crown is continually improving its products, specifications are subject to change without notice.

Crown, the Crown logo, the color beige, the Momentum Mark, Access 1 2 3, InfoPoint, InfoLink Wave and Work Assist are trademarks of Crown Equipment Corporation.

Copyright 2018 Crown Equipment Corporation
 SF19383 Rev. 08-18
 Printed in U.S.A.