

CROWN

WP 3200 SERIES

Specifications

Pedestrian Pallet Truck with High Lift



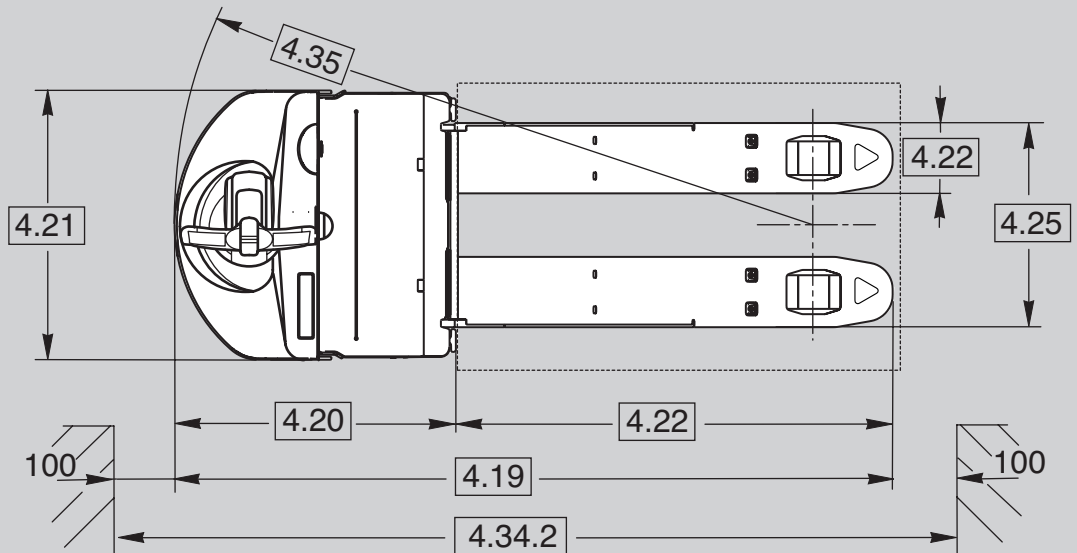
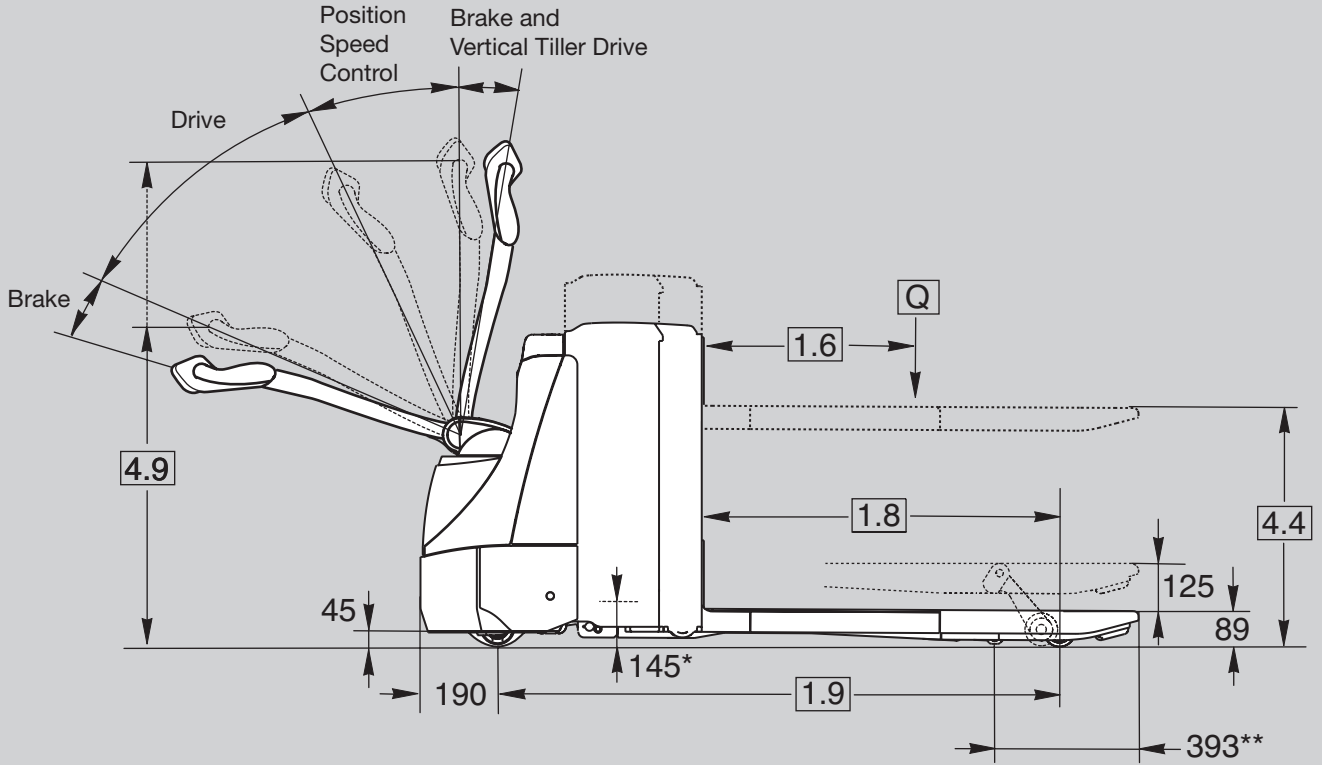

* battery rollout height
 ** 1200 mm fork length +50 mm

Distinguishing Mark	1.1	Manufacturer	Crown Equipment Corporation			
	1.2	Model	WP 3280-2.0			
	1.3	Power Source	electric			
	1.4	Operator Type	pedestrian			
	1.5	Rated Capacity	pallet truck	Q	t	2.0
			stacker	Q	t	0,8
	1.6	Load Centre		c	mm	600
	1.8	Load Distance	outriggers raised / lowered	x	mm	900 / 940
	1.9	Wheelbase	outriggers raised / lowered	y	mm	1343 / 1399 1443 / 1499
Weight	2.1	Service Weight	less battery		kg	490 535
	2.2	Axle Load	with Load front / rear		kg	947 / 1696 (968/1702) 982 / 1765
	2.3		without Load front / rear		kg	495 / 148 (516/154) 562 / 185
Tyres / Wheels / Chassis	3.1	Tyres	Vulkollan			
	3.2	Tyre Size	front		mm	Ø 250 x 85
			rear		mm	Ø 82 x 110
	3.4	Additional Wheels	castor wheels		mm	Ø 90 x 50
	3.5	Wheels	number (x=driven) front/rear			1x + 2/2
	3.6	Tread	front	b ₁₀	mm	478
			rear	b ₁₁	mm	370
Dimensions	4.3	Free-lift		h ₂	mm	536
	4.4	Lift Height		h ₃	mm	750
	4.6	Initial Lift		h ₅	mm	125
	4.9	Height Control Handle	in driving position min./max.	h ₁₄	mm	780 / 1197
	4.15	Fork Height	lowered	h ₁₃	mm	89
	4.19	Overall Length 2 3	outriggers lowered	l ₁	mm	1799 1899
	4.20	Head Length	outriggers raised / lowered	l ₂	mm	665 / 649 765 / 749
	4.21	Overall Width		b ₁ /b ₂	mm	712
	4.22	Fork Dimension	DIN ISO 2331	s/e/l	mm	60 x 186 x 1150
	4.25	Fork Spread		b ₅	mm	540
	4.32	Ground Clearance	Centre Wheelbase	m ₂	mm	30
	4.34.2	Aisle Width predetermined Load Dimension *	for Pallets 800x1200 lengthways, outriggers raised / lowered	A _{st}	mm	2034 / 2050 2134 / 2150
4.35	Turning Radius 1	outriggers raised	W _a	mm	1534 1634	
Performance Data	5.1	Travel Speed 7	with / without Load		km/h	5.5 / 6.0
	5.1.1	Travel Speed Backwards 7	with / without Load		km/h	5.5 / 6.0
	5.2	Lift Speed	with / without Load		m/s	0.11 / 0.17
	5.3	Lowering Speed	with / without Load		m/s	0.15 / 0.13
	5.8	Max. Gradeability	with / without Load, 5 min. rating		%	10 / 25
	5.10	Service Brake				electric
Electric Motor	6.1	Traction Motor	rating at S2 60 min. / H-class		kW	1.5
	6.2	Pump Motor	rating at S3 15 %		kW	1.3
	6.3	Battery	according to DIN 43531/35/36 A, B, C, no	lxwxh	mm	146 x 660 x 591 (146 x 660 x 683) ⁴ 212 x 624 x 627 ^{5,6}
	6.4	Battery Voltage	Nominal Capacity K5		V/Ah	24 / 150 (200) 24 / 250
	6.5	Battery Weight			kg	153 (180) 212
8.1	Drive Unit				transistor	

¹ outriggers lowered +56 mm

² outriggers raised +16 mm

³ 1200 mm fork length +50 mm

⁴ Layout A, cell type acc. to BS

⁵ Layout B, cell types acc. to DIN 43535

⁶ 250 Ah battery only for rollout compartment

⁷ 5.1 = Power unit first / 5.1.1 = Forks first

* Ast calculation applies to 1150 mm and 1200 mm fork length
with optional 200 Ah battery compartment use values in brackets

Standard Equipment

1. X10® control handle places all truck functions at the operator's fingertips
2. 24-Volt fused electrical system
3. e-GEN® Braking System offers regenerative and frictionless electric braking
4. Electric parking brake
5. Maintenance free 3-phase (AC) traction motor
6. 150 Ah lift-out battery compartment
7. Rabbit/turtle switch incorporates two levels of programmable travel performance
8. Position Speed Control
9. Vertical Tiller Drive
10. Key switch
11. Horn button in each handgrip
12. Battery connector SBE 160 red
13. Emergency disconnect
14. Vulkollan drive tyre and single load wheels
15. Castor wheels connected with torsion bar
16. Auto reverse safety switch
17. Battery discharge indicator with lift lock out and integrated hourmeter and fault code readout
18. Ramp hold
19. Steel battery top cover
20. Fork tip indicators

Optional Equipment

1. Auxiliary fork lift switches on battery cover
2. 200 Ah lift-out battery compartment
3. 250 Ah rollout battery compartment (right hand side, forks first direction)
4. Battery connector DIN 160 A
5. Freezer conditioning -30°C operating temperature
6. 1200 mm fork length
7. Drive wheel rubber Ø 250 x 100 mm
8. Drive wheel Supertrac Ø 250 x 85 mm
9. Tandem load wheels Ø 82 x 82 mm, Vulkollan
10. Sealed high frequency on-board charger
11. Keypad
12. InfoLink® Ready
13. 970 mm high load backrest
14. Special paint
15. Welded fork marks
16. Low skirt clearance 33 mm
17. Outrigger lift/lower switches on left and right side of X10® control handle
18. Lithium-Ion Battery Ready

Operator Controls

The high-lift fork design provides postural relief for operators who manually transfer goods from pallet to shelf. The forks are positioned such that the top of the load is at a comfortable working height. As layers of goods are removed, the forks are raised to keep the working height constant. Optional lift buttons located on top of the battery cover enable operators to easily raise the load while standing adjacent to the pallet. The WP's robust X10® control handle is designed to allow for an optimum turning radius with low steer effort. All control buttons can be operated with either hand and can be accessed with minimum hand and wrist movement. The horn buttons are integrated in the hand grips. An ergonomic forward/reverse thumb wheel allows for precise manoeuvring. A rabbit/turtle switch allows operators to select the maximum travel speed in order to match the operating conditions. The e-GEN® braking system is activated when the forward/reverse thumb wheel is returned to neutral, during plugging or whenever the tiller is positioned in the upper or lower braking position. Brake rate is adjustable with handset.

Frame & Chassis

The optimised steel structure results in a rugged design which has minimum deflection and low stresses and features a 5 year warranty of the chassis and fork assembly. A removable steel cover ensures internal components are protected against impacts yet easily accessible for service. The 8 mm thick steel skirt and the round contour gives the truck maximum protection and avoids damaging goods. The forks with pull rod linkage are manufactured from a high tensile strength steel and feature an integrated exit and entry ramp for safe and easy pallet handling. Twin, hard-chromed initial lift cylinders and a torsion bar provide improved load stability. The Vulkollan load wheels incorporate a debris cover to protect the bearing.

Electrical System and e-GEN® Braking

A heavy-duty 24-volt fused electrical system provides optimum travel and lift speeds. The transistor control is sealed from dirt, dust and moisture for trouble-free operation. An on-board diagnostic system reduces troubleshooting times to a minimum. An optional handset allows various performance levels to be tailored to the requirements of the customer and application. The e-GEN® braking system utilises the controller and AC motor to deliver the optimum level of braking based on inputs. The power of the high-torque AC traction motor is used to stop the truck and keep it static until a travel input is requested, even when operating on a gradient.

Gearbox, Traction Motor and Brake

The heavy duty gearbox is designed for minimum noise. A rugged helical gear set delivers trouble free operation and long life. The transistor control module works in conjunction with the AC drive motor to provide responsive acceleration and precise control. The excellent acceleration enhances efficient pallet entry and exit to increase productivity. The parking brake mounted directly on is spring applied and electro-magnetically released. The park brake is only activated when the thumb wheel is returned to neutral and no tyre movement is sensed, so rotor and disc life is extended. Park brake components are easily accessed for inspection and replacement.

Battery and Charger

The battery as well as the connector is easily accessible. The battery lid can be easily opened or if necessary removed by simply undoing a latch. A built-in 30 amp sealed charger is available as an option. This premium solid-state charger is durable and efficient. The sealed unit eliminates problems or failures related to contamination or moisture. It has an advanced memory feature to allow for opportunity charging. The charger can be set for either maintenance-free or industrial batteries.

Hydraulic Lift System

Heavy-duty hydraulic motor with integral pump and reservoir for maximum efficiency and durability. The flow control valve allows for smooth lowering even when the truck is fully loaded. A relief valve protects the components and chassis from overloading. The lift limit switch avoids unnecessary energy consumption, reduces noise emissions and prevents the lift linkage from undue stress. The smooth low noise hydraulic system makes the truck ideal for retail shop operation. Load wheel risers are made from high quality steel for maximum load capability. All bolts are plated to provide protection against rust and corrosion.

Position Speed Control

When operating in tight spaces such as retail stores with narrow aisles or inside lorries and elevators, the operator can move the tiller from the Travel zone to the Position Speed Control zone. The travel speed in fork direction will then be automatically reduced to 1.5 km/h without the need to come to a halt and a further command from the operator. This ensures a smooth and productive workflow while avoiding unintentional interruptions.

Vertical Tiller Drive

The Vertical Tiller Drive function goes one step beyond. When activated, the truck can be moved at up to 1.5 km/h even in the upper braking zone by simply keeping the travel switch pressed in the desired direction. Reducing the turning radius of the truck, the system enables operators to easily move pallets while reducing goods damage cost.

Safety Regulations

Conforms to European safety standards. Dimensions and performance data given may vary due to manufacturing tolerances. Performance is based on an average size vehicle and is affected by weight, condition of truck, how it is equipped and the conditions of the operating area. Crown products and specifications are subject to change without notice.