

CROWN

ES 4000 SERIES

Specifications

Pedestrian Stacker



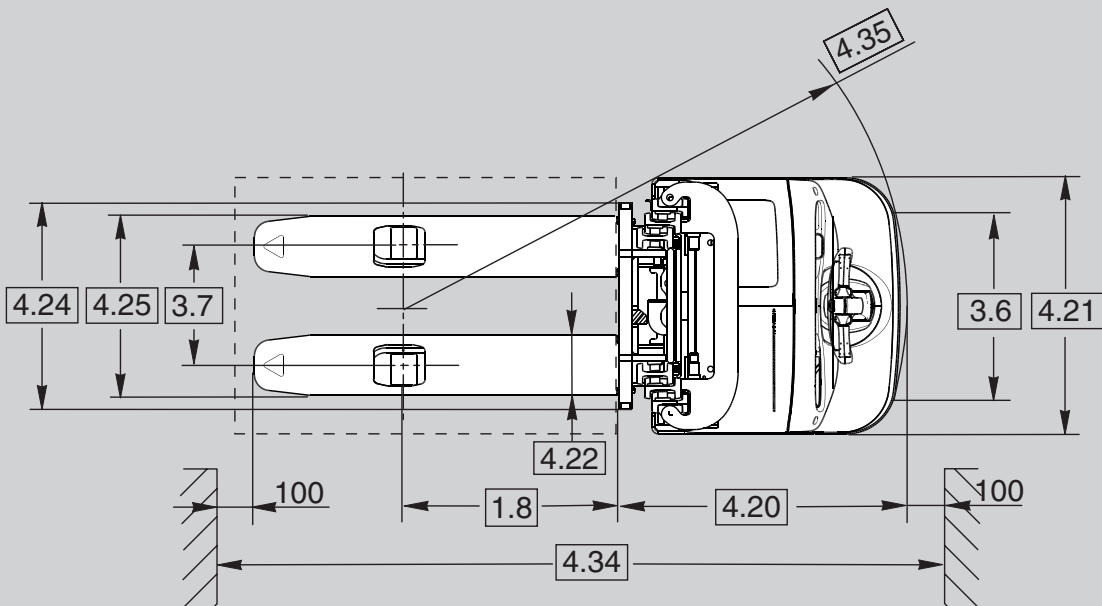
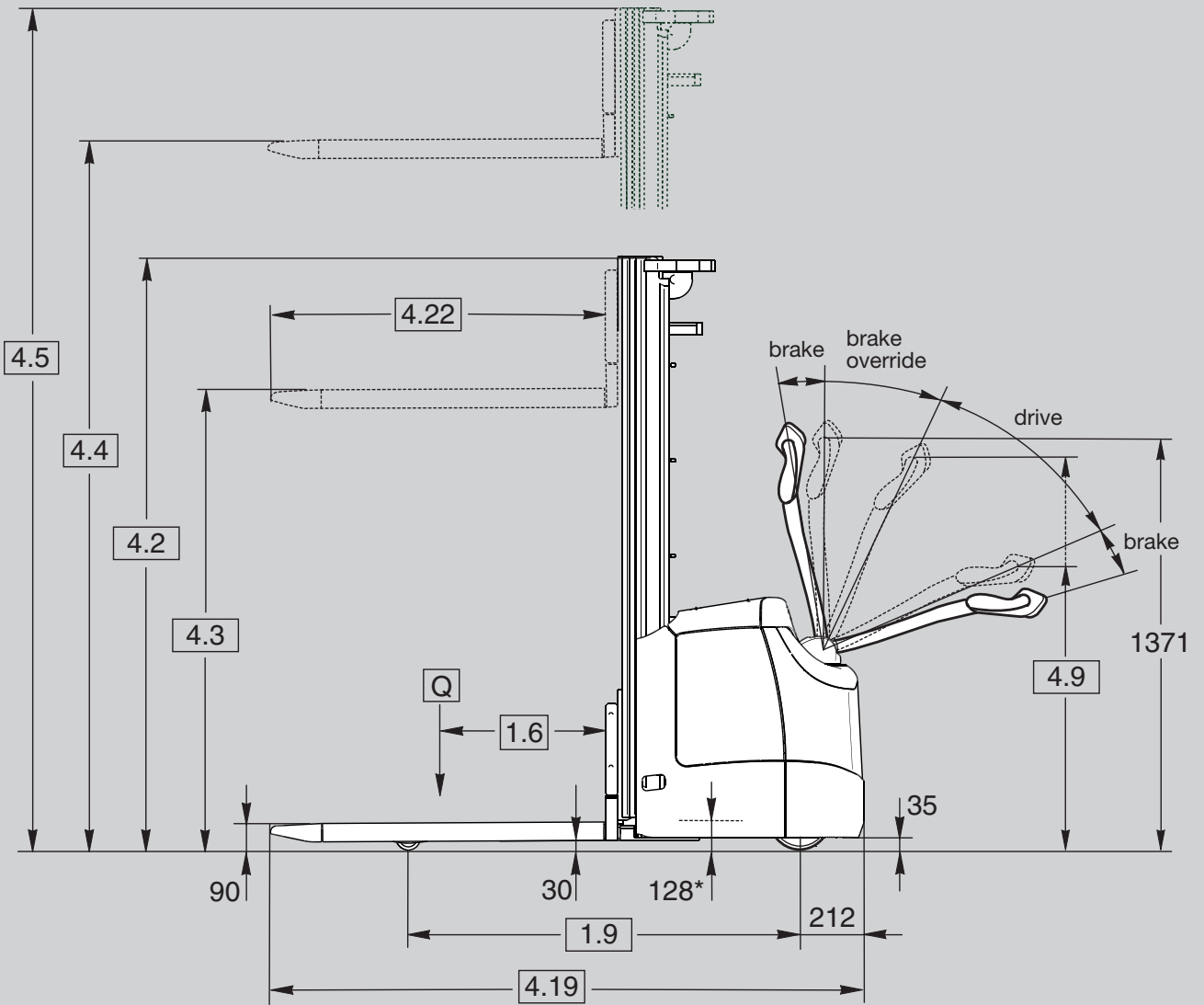

* battery roll out height

General Information	1.1	Manufacturer	Crown Equipment Corporation					
	1.2	Model			ES 4000 – 1.2	ES 4000 – 1.4	ES 4000 – 1.6	
	1.3	Power			electric			
	1.4	Operator Type			pedestrian			
	1.5	Load Capacity		Q	t	1.2	1.4	1.6
	1.6	Load Centre		c	mm	600		
	1.8	Load Distance		x	mm	675	670	679
	1.9	Wheel Base ¹		y	mm	1239		1279
	Weights	2.1	Weight	less battery		kg	see table 1	see table 2
2.2		Axle Load	w. load, front / rear		kg	see table 1	see table 2	see table 3
2.3		Axle Load	w.o. load, front / rear		kg	see table 1	see table 2	see table 3
Tyres	3.1	Tyre Type				Vulkollan		
	3.2	Wheel Size ²	front		mm	Ø 230 x 70		
	3.3	Wheel Size	rear		mm	1x Ø 82 x 100		2x Ø 82 x 60
	3.4	Additional Wheels	castor wheel		mm	Ø 140 x 54		
	3.5	Wheels	no. (x=driven) front/rear			1x + 1/2		1x + 1/4
	3.6	Track Width ³	front	b10	mm	542		
	3.7	Track Width	rear	b11	mm	390		395
Dimensions	4.2	Mast	collapsed height	h1	mm	see table 1	see table 2	see table 3
	4.3	Free Lift		h2	mm	see table 1	see table 2	see table 3
	4.4	Lift Height		h3+h13	mm	see table 1	see table 2	see table 3
	4.5	Mast	extended height	h4	mm	see table 1	see table 2	see table 3
	4.9	Tiller Arm Height	in drive position min./max.	h14	mm	786 / 1231		
	4.15	Fork Height	lowered	h13	mm	90		
	4.19	Overall Length ¹	TL/TF/TT	l1	mm	1908 / 1908 / 1926	1913 / 1913 / 1931	1938 / 1938 / 1962
	4.20	Headlength ¹	TL/TF/TT	l2	mm	758 / 758 / 776	763 / 763 / 781	788 / 788 / 812
	4.21	Overall Width		b1	mm	800		
	4.22	Fork Dimension	standard	thxwxl	mm	60 x 186 x 1150	60 x 190 x 1150	
	4.24	Fork Carriage Width		b3	mm	650		
	4.25	Width Across Forks		b5	mm	560	565	
	4.32	Ground Clearance	centre wheel base	m2	mm	30		
4.34	Working Aisle Width ¹	800x1200 length	Ast	mm	2321	2325	2358	
4.35	Turning Radius ¹		Wa	mm	1461	1461	1501	
Performance	5.1	Travel Speed	w./w.o. load		km/h	6 / 6	6 / 6	6 / 6
	5.2	Lift Speed	w./w.o. load		m/s	0.16 / 0.24	0.14 / 0.24	0.12 / 0.24
	5.3	Lowering Speed	w./w.o. load		m/s	0.36 / 0.28		
	5.8	Max. Gradeability	w./w.o. load 5 min. rating		%	10 / 16	9 / 16	8 / 16
	5.10	Service Brake				electric		
Motors	6.1	Traction Motor	rating at S2 60 min./H-class		kW	3.0		
	6.2	Lift Motor	rating at S3 10 %		kW	3.0		
	6.3	Battery	acc. to DIN 43535			B		
		Max. Battery Box Size ⁴		lxwxh	mm	212 x 624 x 627 (284 x 624 x 627)		
	6.4	Battery Voltage ⁴	nominal capacity 5h rating		V / Ah	24 / 250 (375)		
6.5	Battery Weight ⁴			kg	212 (309)			
Misc.	8.1	Type Controller	drive			AC-transistor		
	8.4	Sound Level	acc. to EN 12053		dB(A)	≤ 70		

¹ add 72 mm for larger battery compartment

² Ø 250 x 75 mm with electric steering

³ subtract 9 mm with electric steering

⁴ with optional larger battery compartment use values in brackets

Table 1 Mast Chart

1.2 Model					ES 4000 - 1.2														
Mast Type					TL					TF					TT				
2.1	Weight *	less battery		kg	816	838	858	882	908	826	847	867	890	915	948	967	980	995	1012
2.2	Axle Load 250 Ah	w. load	front	kg	835	850	864	880	898	842	856	870	886	903	908	921	930	940	952
			rear	kg	1393	1400	1406	1414	1422	1396	1403	1409	1416	1424	1452	1458	1462	1467	1472
2.3	Axle Load 250 Ah	w.o. load	front	kg	745	760	774	790	808	752	766	780	796	813	835	848	857	867	879
			rear	kg	283	290	296	304	312	286	293	299	306	314	325	331	335	340	345
2.2	Axle Load 375 Ah	w. load	front	kg	925	940	953	969	986	932	946	959	974	990	994	1007	1015	1025	1036
			rear	kg	1448	1455	1462	1470	1479	1451	1458	1465	1473	1482	1511	1518	1522	1527	1533
2.3	Axle Load 375 Ah	w.o. load	front	kg	840	855	868	883	900	847	861	874	889	905	925	938	946	956	967
			rear	kg	333	340	347	356	365	336	343	350	358	367	380	387	391	396	402
4.2	Mast	collapsed height	h1	mm	1770	1980	2180	2420	2670	1770	1980	2180	2420	2670	1845	1980	2140	2220	2370
4.3	Free Lift **		h2	mm	180					1290	1500	1690	1940	2190	1360	1500	1660	1735	1870
4.4	Lift Height		h3+h13	mm	2440	2860	3260	3740	4240	2540	2960	3360	3840	4340	4000	4440	4750	5000	5400
4.5	Mast ***	extended height	h4	mm	2920	3350	3750	4220	4720	3020	3450	3850	4320	4820	4480	4930	5240	5480	5880

Table 2 Mast Chart

1.2 Model					ES 4000 - 1.4														
Mast Type					TL					TF					TT				
2.1	Weight *	less battery		kg	835	858	880	906	934	845	868	889	914	941	968	988	1002	1018	1036
2.2	Axle Load 250 Ah	w. load	front	kg	851	867	882	900	920	858	874	889	906	924	921	935	945	956	969
			rear	kg	1596	1603	1610	1618	1626	1599	1606	1612	1620	1629	1659	1665	1669	1674	1679
2.3	Axle Load 250 Ah	w.o. load	front	kg	752	768	783	801	820	759	775	789	806	825	843	857	866	877	889
			rear	kg	295	302	309	317	326	298	305	312	320	328	337	344	348	353	359
2.2	Axle Load 375 Ah	w. load	front	kg	941	956	970	987	1006	947	962	976	993	1010	1008	1021	1030	1040	1052
			rear	kg	1651	1659	1667	1676	1685	1655	1663	1670	1678	1688	1717	1724	1729	1735	1741
2.3	Axle Load 375 Ah	w.o. load	front	kg	847	862	876	893	912	853	868	882	899	916	933	946	955	965	977
			rear	kg	345	353	361	370	379	349	357	364	372	382	392	399	404	410	416
4.2	Mast	collapsed height	h1	mm	1770	1980	2180	2420	2670	1770	1980	2180	2420	2670	1845	1980	2140	2220	2370
4.3	Free Lift **		h2	mm	180					1290	1500	1690	1940	2190	1360	1500	1660	1735	1870
4.4	Lift Height		h3+h13	mm	2440	2860	3260	3740	4240	2540	2960	3360	3840	4340	4000	4440	4750	5000	5400
4.5	Mast ***	extended height	h4	mm	2920	3350	3750	4220	4720	3020	3450	3850	4320	4820	4480	4930	5240	5480	5880

Table 3 Mast Chart

1.2 Model					ES 4000 - 1.6														
Mast Type					TL					TF					TT				
2.1	Weight *	less battery		kg	894	924	954	984	1019	910	940	967	1000	1035	1075	1101	1119	1140	1164
2.2	Axle Load 250 Ah	w. load	front	kg	929	950	971	992	1017	940	961	980	1003	1028	1024	1043	1055	1069	1086
			rear	kg	1777	1786	1795	1804	1814	1782	1791	1799	1809	1819	1862	1870	1876	1883	1890
2.3	Axle Load 250 Ah	w.o. load	front	kg	801	822	843	864	888	811	832	851	875	899	924	943	956	971	988
			rear	kg	305	314	323	332	343	311	320	328	337	348	362	370	375	381	388
2.2	Axle Load 375 Ah	w. load	front	kg	1017	1036	1056	1076	1100	1027	1047	1065	1087	1110	1105	1123	1135	1149	1165
			rear	kg	1834	1845	1855	1865	1876	1840	1850	1859	1870	1882	1926	1935	1941	1948	1956
2.3	Axle Load 375 Ah	w.o. load	front	kg	895	914	934	954	978	905	925	943	965	988	1012	1030	1042	1056	1072
			rear	kg	356	367	377	387	398	362	372	381	392	404	419	428	434	441	449
4.2	Mast	collapsed height	h1	mm	1770	1980	2180	2420	2670	1770	1980	2180	2420	2670	1845	1980	2140	2220	2370
4.3	Free Lift **		h2	mm	180					1290	1500	1690	1940	2190	1360	1500	1660	1735	1870
4.4	Lift Height		h3+h13	mm	2440	2860	3260	3740	4240	2540	2960	3360	3840	4340	4000	4440	4750	5000	5400
4.5	Mast ***	extended height	h4	mm	2920	3350	3750	4220	4720	3020	3450	3850	4320	4820	4480	4930	5240	5480	5880

* add 69 kg for 375 Ah battery compartment ** with load backrest subtract 750 mm for TF and TT *** with load backrest add 750 mm
all data apply to mechanical steering only

Standard Equipment

1. The X10® Control Handle places all truck functions at the operator's fingertips
2. Proportional lifting/lowering provided by a low-noise hydraulic system
3. e-GEN® Braking System offers regenerative and frictionless electric braking. Mechanical braking applies only as parking brake.
4. Crown Access 1 2 3® Comprehensive System Control
 - LCD display
 - Hour meter
 - Keyless start up with PIN code
 - Start up and run time diagnostics
 - Battery discharge indicator and lift interrupt
 - 3 selectable traction performance profiles
 - Onboard diagnostics with real time troubleshooting capabilities
5. Crown maintenance free 3-phase (AC) traction motor
6. CAN-Bus technology
7. Centre mounted tiller
8. Electric power disconnect push button
9. Ramp hold
10. Vulkollan drive tyre, castor wheel(s) and load wheels
11. Single load wheels (1.2 t and 1.4 t), tandem load wheels (1.6 t)
12. Heavy-duty chassis with 8 mm thick steel skirt
13. Easily removable steel cover
14. Hinged steel top battery cover for easy battery access
15. Plexiglas mast guard
16. 250 Ah DIN battery compartment
17. Battery connector DIN 160A
18. Sealed electrical Deutsch connectors
4. Onboard charger (lift out only)
5. Battery connector SBE 160 red / SB 175 red / SB 175 grey
6. Rubber or Supertrac drive tyre
7. Tandem load wheels (1.2 t and 1.4 t)
8. Heavy-duty dual castor wheels
9. Fork length and spread options
10. 1200 mm high load backrest
11. Key switch or key pad
12. Freezer conditioning
13. InfoLink® ready
14. Work Assist accessory tube
15. Work Assist Accessories
 - Storage pockets
 - Scan gun holder
 - Medium and large clipboards
 - Beverage holder
16. Metal mast grill
17. Flashing beacon
18. Travel alarm
19. 12V clean power supply
20. 24V power supply
21. Special paint
22. Lithium-Ion Battery Ready

Optional Equipment

1. Electronic Steering System with 3-phase (AC) motor
2. 375 Ah battery compartment
3. Battery roll out (right hand side, forks first direction)

Electric System / Battery

24 volt electrical system with nominal battery capacities from 250 Ah to 375 Ah is managed by Crown's Access 1 2 3 Comprehensive System Control. Virtually maintenance-free Crown AC traction motor provides strong acceleration and control at any speed. Sensors monitor functional parameters including steering, load weight, height, drive mode and speed and adjust operational settings automatically to suit conditions.

Power Unit

The rugged power unit features a reinforced 8 mm thick skirt to protect drive unit and castor components. Removable steel covers all around ensure internal components are protected against impacts yet easily accessible for service. On the inside a Crown-built AC traction motor and a low-noise cast iron gearbox provide reliable power.

Operator Area and Controls

The ES 4000 Series incorporates numerous design features to improve operator comfort and productivity. The centre mounted X10 Control Handle is designed for simultaneous operation of all functions with one hand and positions the operator in a safe distance to the power unit even with the tiller turned 90°. An ergonomic forward/reverse thumb wheel allows for precise manoeuvring. The hand grips are urethane covered for insulation from cold and vibration with integrated horn buttons for easy activation. A rabbit/turtle switch incorporates two levels of programmable travel performance so operators can select the setting that matches their experience level or application requirements. Available electronic steering improves manoeuvrability and responsiveness, even with heavy loads. Proportional lift and lowering allows easy and precise positioning of loads. The fast responsiveness and speeds of the lifting and lowering functions are designed to ensure high efficiency in all applications and all this together at a low noise level. For easy operation in tight areas a brake override function is incorporated which allows the ES 4000 to be driven safely and precisely at creep speed with the handle in a near vertical position. The control handle remains within the profile of the power unit at all times, even when performing 90° turn.

Access 1 2 3® Comprehensive System Control

Crown's Access 1 2 3 technology provides optimum performance and control by offering a communications interface for the operator and service engineer, intelligent coordination of lift truck systems and simplified service with advanced diagnostics.

The display includes a full featured on-board service tool allowing service engineers to actively view inputs and outputs during truck operation. No laptop or service terminal is required. Event code history, including the last 16 events, is accessible through the display.

The display provides a convenient interface for operators, keeping them informed (hour meter, BDI, operator messages, service codes) of any changes impacting truck performance and allowing them to choose from three performance profiles when enabled.

Performance tuning can be accessed at the display to customise truck performance for specific applications or operator requirements. In addition, up to 25 PIN codes can be assigned to individual operators and matched to one of the pre-programmed performance profiles if desired.

e-GEN® Braking System

The power of the high-torque AC traction motor is used to stop the truck and keep it static until a travel input is requested, even when operating on a gradient. This system eliminates adjustments and wear points for a lifetime of maintenance free use. An automatic parking brake activates if the truck is stopped or power is disconnected.

Safety Regulations

Conforms to European safety standards. Dimensions and performance data given may vary due to manufacturing tolerances. Performance is based on an average size vehicle and is affected by weight, condition of truck, how it is equipped and the conditions of the operating area. Crown products and specifications are subject to change without notice.

