



Scissor Lift PTH 50 Series

Elevate Comfort and Productivity

Crown's PTH 50S/PS hand pallet truck with manual or powered scissor lift improves operator comfort and efficiency by avoiding unnecessary bending and lifting that can cause strains and stresses on the body.

- Use as a hand pallet truck and mobile work positioner
- Handle skids and open-bottom containers
- Transport loads, use as a worktable and feed printing or punch presses, as well as conveyors



PTH50S
Manual Hydraulic System



PTH50PS
Power Hydraulic System

PTH50S Model

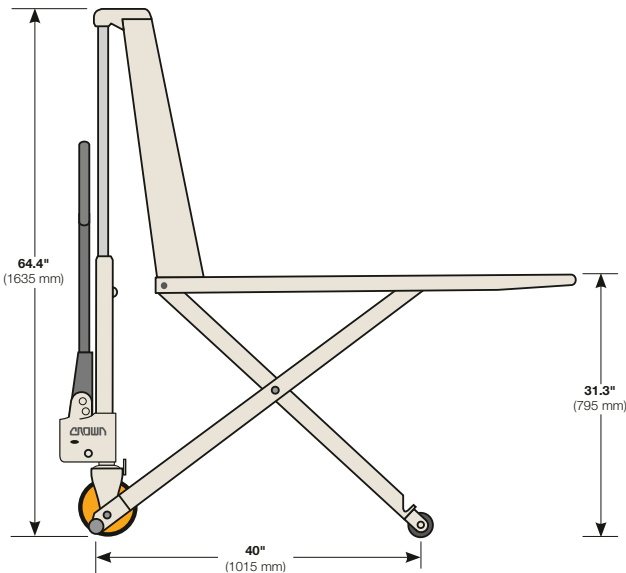
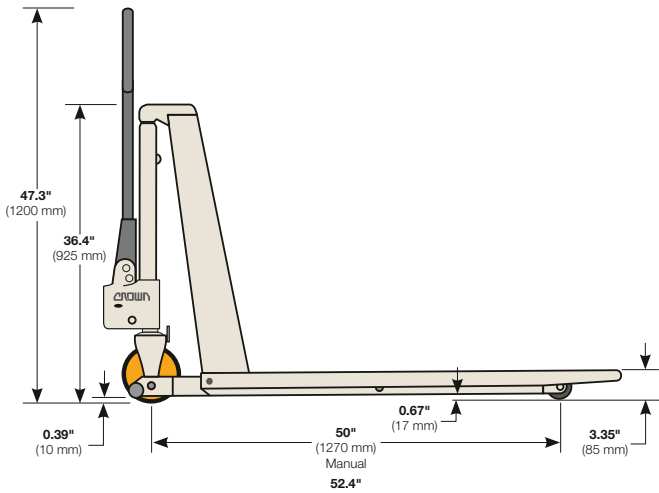
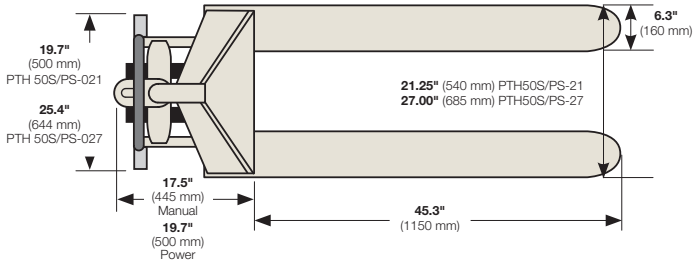

Technical Information

		Imperial	Metric	Imperial	Metric
Manufacturer		Crown Equipment Corporation			
Scissor Lift Model		PTH50S		PTH50PS	
Power, Hydraulic		Manual		Manual/Electric	
Load Capacity	lb kg	2200	1000	2200	1000
Load Center	in mm	23.6	600	23.6	600
Fork Length	in mm	45.3	1150	45.3	1150
Overall Length	in mm	62.8	1595	65.2	1655
Outside Fork Spread	in mm	21.25/27.00	540/685	21.25/27.00	540/685
Fork Width	in mm	6.3	160	6.3	160
Fork Height	Lowered in mm	3.35	85	3.35	85
	Raised in mm	31.3	795	31.3	795
Steer Angle	degree	200		200	
Ground Clearance	in mm	0.67	17	0.67	17
Poly Steer Wheels	in mm	7.1 x 2.0	180 x 50	7.1 x 2.0	180 x 50
Poly Load Wheels	Single in mm	2.9 x 2.95	74 x 75	2.9 x 2.95	74 x 75
Truck Weight	lb kg	330/348	150/158	429/195	195/202

Standard Features

Control Handle

- Ergonomic handle features optimal thickness and angled shape for fatigue-free operation
- Three position control lever (raise, lower and neutral) is easily actuated with one finger

Handling

- Two hundred degree steer angle for maneuvering in tight areas

Frame and Fork Assembly

- One-piece formed C-channel steel, reinforced forks for maximum strength and longer life
- Heavy-duty, solid steel scissor legs

Operator Safety and Control

- Two stabilizer supports disengage the steer wheels at a lift height of approximately 15" (400 mm) to help prevent unexpected truck movement

Manual Hydraulic System (PTH50S)

- Manual actuation of hydraulic lift using the handle
- Single-piece cast pump with serviceable valve cartridge
- Overload bypass valve prevents lifting of loads beyond the rated capacity

- Top-of-stroke bypass protects the hydraulic system and extends the life of the system components

- Hard-chrome ram and piston improve service life and minimize rust

Electric Powered Hydraulic System (PTH50PS)

- Fast and quiet height adjustment at the press of a button
- Ideal for applications requiring frequently varied working heights
- Maintenance-free battery, cycle and vibration safe, 12 volt/60Ah
- Discharge indicator with lift cut-out to prevent full discharge
- On-board charger, 12 volt/10 amps
- All manual lifting and lowering functions are retained



Crown Equipment Corporation
 New Bremen, Ohio 45869 USA
Tel 419-629-2311
Fax 419-629-3796
 crown.com

Because Crown is continually improving its products, specifications are subject to change without notice.

Crown, the Crown logo, the color beige, the Momentum Mark and ecologic are trademarks of Crown Equipment Corporation.

Copyright 2013-2015 Crown Equipment Corporation
 SF18992 Rev. 10-19
 Printed in U.S.A.