

CROWN

SP 3500 SERIES

Specifications

Stockpicker with Aux Lift



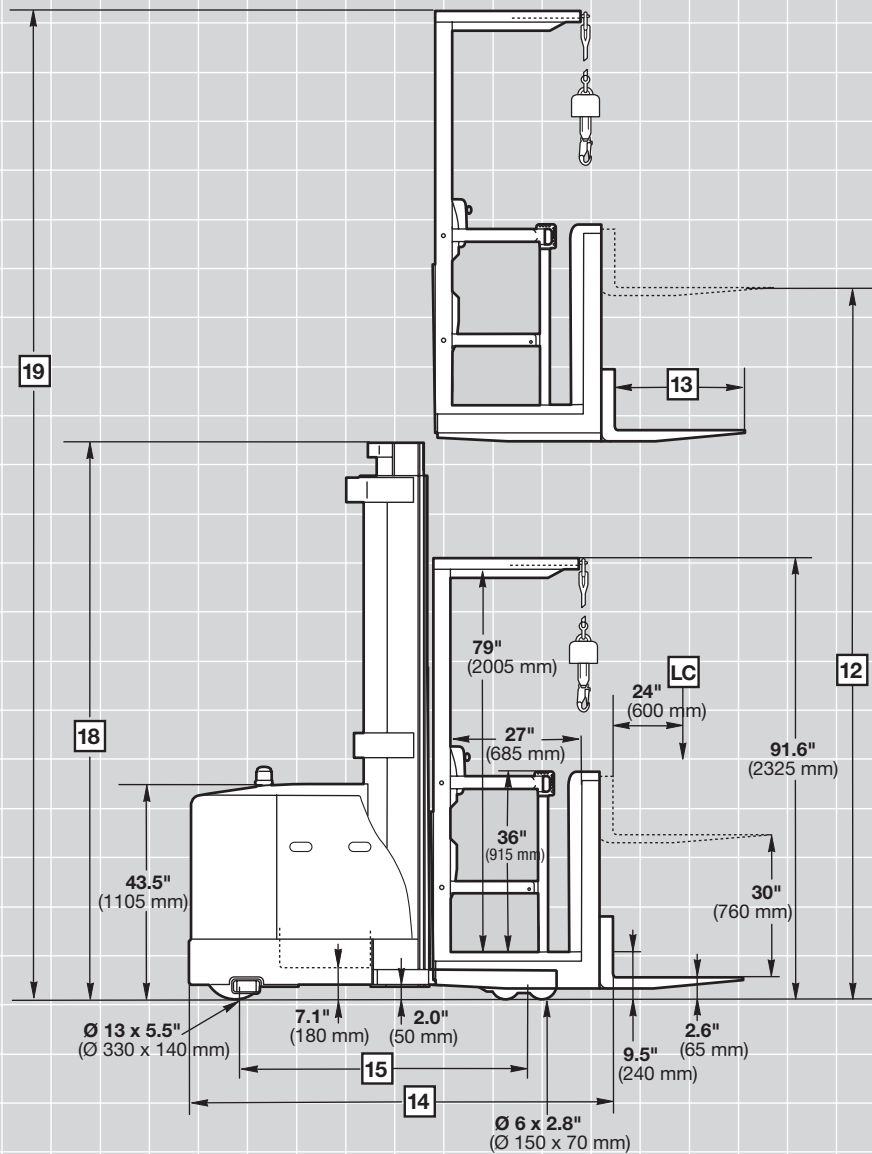
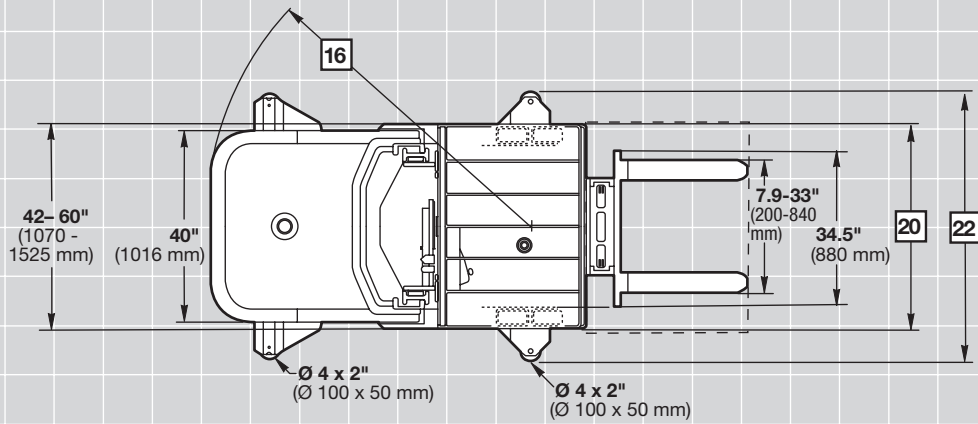

SP 3500 Series

Specifications

			Imperial	Metric			
General	1	Manufacturer	Crown Equipment Corporation				
	2	Model	SP 3500-22				
	3	Load Capacity*	2200 lb kg	1000			
	4	Load Center	Fork face to load CG in mm	24 600			
	5	Power	Electric	24 Volts			
	6	Operator Type		Stockpicker			
	7	Tire Type		Polyurethane			
Performance	8	Speed Travel	Empty/Loaded mph km/h	See Mast Chart			
	9	Speed Lift		Standard	High Speed	Standard	High Speed
			TL Empty fpm m/s	51	80	0.26	0.41
			TL Loaded fpm m/s	27	45	0.14	0.23
			TT Empty fpm m/s	39	71	0.20	0.36
	10	Speed Lower	TT Loaded fpm m/s	26	43	0.13	0.22
			TL Empty fpm m/s	39	80	0.20	0.41
			TL Loaded fpm m/s	36	74	0.19	0.38
			TT Empty fpm m/s	39	80	0.20	0.41
	TT Loaded fpm m/s	36	74	0.19	0.38		
Dimensions	11	Wheels (x = driven)	Number Front/Rear	4 / 1x			
	12	Lifting Height	in mm	See Chart			
	13	Forks	Standard L x W x T in mm	36x4x1.5		915x100x40	
			Optional Lengths in mm	30, 39, 42, 45, 48		760, 990, 1070, 1145, 1220	
	14	Headlength	TL Length to Fork Face in mm	83.5		2120	
			TT Length to Fork Face in mm	84.5		2145	
	15	Wheelbase	TL in mm	55.5		1410	
TT in mm			54.5		1385		
16	Turning Radius	TL in mm	69		1755		
		TT in mm	68		1730		
Battery	17	Battery	Type	Lead Acid			
			Min Weight/Max Amp lb kg	1520		690	
			Ah	1085		1085	
			Max Battery Size L x W x H in mm	14.2 x 36.2 x 31.0		360 x 920 x 790	
		Standard Connector	SB 350 Red				

*Contact factory. Capacity may be subject to derating, depending upon lifting height, load center and fork length.

SP 3500 – TL Mast – Standard/High Speed Lift

12	Lifting Height	in mm	166	4215	178	4520	202	5130	224	5690	244	6200
	Rated Capacity at Max Lift Ht.	lb kg	2200	1000	2200	1000	2200	1000	2200	1000	2200	1000
	Free Lift Height	in mm	33	835	34.5	875	34.5	875	34.5	875	34.5	875
18	Mast Collapsed Height	in mm	91.5	2325	95	2415	107	2720	119	3025	131	3330
19	Mast Extended Height	in mm	224.5	5700	236.5	6010	260.5	6615	282.5	7175	302.5	7685
20	Straddle Width	in mm	42	1070	42	1070	42	1070	42	1070	42	1070
	Operator Compartment Width	in mm	42	1070	42	1070	42	1070	42	1070	42	1070
22	Aisle Guide Wheel Range	in mm	42.9 to 65.4	1089 to 1660	42.9 to 65.4	1089 to 1660	42.9 to 65.4	1089 to 1660	42.9 to 65.4	1089 to 1660	42.9 to 65.4	1089 to 1660
	Truck Weight Without Battery	lb kg	5467	2485	5535	2515	5665	2575	5950	2705	6085	2765

SP 3500 – TT Mast – Standard/High Speed Lift

12	Lifting Height	in mm	225	5715	240	6095	270	6860
	Rated Capacity at Max Lift Ht.	lb kg	2200	1000	2200	1000	1800	825
	Free Lift Height	in mm	32.9	835	36.5	925	48.5	1230
18	Mast Collapsed Height	in mm	91.5	2325	95	2415	107	2720
19	Mast Extended Height	in mm	284.5	7225	300	7610	330	8370
20	Straddle Width	in mm	42	1070	42	1070	48	1220
	Operator Compartment Width	in mm	42	1070	42	1070	48	1220
22	Aisle Guide Wheel Range	in mm	42.9 to 65.4	1089 to 1660	42.9 to 65.4	1089 to 1660	48.8 to 71.3	1239 to 1810
	Truck Weight Without Battery	lb kg	6050	2750	6140	2790	6315	2870

SP 3500 – TT Mast – High Speed Lift

12	Lifting Height	in mm	306	7770	324	8230	342	8685	360	9145	378	9600
	Rated Capacity at Max Lift Ht.	lb kg	1400	650	1200	550	1100	500	950	450	750	350
	Free Lift Height	in mm	60.5	1535	66.5	1685	72.5	1840	84.5	2145	90.5	2295
18	Mast Collapsed Height	in mm	119	3025	125	3175	131	3330	143	3635	149	3785
19	Mast Extended Height	in mm	365.5	9285	383.5	9740	401.5	10200	419.5	10655	437.5	11112
20	Straddle Width	in mm	54	1370	54	1370	54	1370	60	1525	60	1525
	Operator Compartment Width	in mm	54	1370	54	1370	54	1370	60	1525	60	1525
22	Aisle Guide Wheel Range	in mm	54.7 to 77.2	1389 to 1960	54.7 to 77.2	1389 to 1960	56.7 to 79.2	1439 to 2010	60.8 to 83.3	1544 to 2115	60.8 to 83.3	1544 to 2115
	Truck Weight Without Battery	lb kg	6745	3065	6920	3145	7020	3190	7260	3300	7415	3370

SP 3500 Series

Specifications

Lift Height (inches/ mm)	Steered Wheel < 10° ⁽¹⁾
	Power Unit First (PUF) ⁽²⁾ Travel Speed (mph/kmph) Empty/Loaded
	SP 3500
0 - 24	7.5
0 - 610	12.0
24 - 64	7.5 - 6.0
610 - 1625	12.0 - 9.6
64 - 120	6.0 - 3.8
1625 - 3048	9.6 - 6.1
120 - 152	3.8 - 2.7
3048 - 3861	6.1 - 4.3
152 - 175	2.7 - 2.0
3861 - 4445	4.3 - 3.2
175 - 192	2.0 - 1.5
4445 - 4877	3.2 - 2.4
192 - 216	1.5
4877 - 5486	2.4
216 - max	1.5
5486 - max	2.4

⁽¹⁾ Top travel speed is reduced to 80% at a 10° steering angle, beyond 10° travel speeds gradually reduce down to 50% of top travel speed. Steering angle is automatically limited to within 10° straight travel.

⁽²⁾ From 0-60 inches (0-152 mm), travel speeds in the Forks First (FF) direction of travel are approximately 0.5 mph (0.8 km/h) less than travel speeds in the Power Unit First (PUF) direction.

SP 3500 Series

Technical Information

Standard Equipment

- Crown's Access 1 2 3[®] Comprehensive System Control
- Crown manufactured AC traction motor
- Electronic steering
- Linear speed control for gradual reduction in speed as platform is raised
- Two-speed lower with soft start and stop
- Programmable lift/lower cut outs
- Intelligent Braking System (IBS)
- Crown's Information Display
 - PIN code access capable
 - Standard steer wheel position indicator
 - Enhanced steer wheel position indicator (wire guided trucks)

- Start up and run time diagnostics
 - Hour meters / travel distance / stop watch
 - Battery discharge indicator with lift interrupt
 - 3 selectable traction performance profiles
 - Access 1 2 3 onboard diagnostic with real time troubleshooting capabilities
- Soft urethane twist grip with "cam grip"
 - 10° angled steering wheel with soft feel spinner
 - Storage compartment
 - Crown's anti-fatigue floor mat
 - Clear visibility platform window
 - Clear visibility mast design
 - Key switch
 - Horn
 - Strobe light
 - Hinged, lift off steel power unit doors
 - SB 350 battery connector
 - Battery roll out function, with 2" (50 mm) diameter battery compartment rollers
 - Top battery access for service
 - Removable steel battery side covers
 - Adjustable battery retainer
 - Emergency power disconnect
 - Crown's InfoPoint[®] feature
 - Color-coded wiring
 - Poly drive tire and tandem load wheel
 - Retractable tether and body harness

Model Specific

Standard Equipment

SP 3500

- Hinged side gates with power inhibit
- Fully forged hook-on ISO Type forks
- Auxiliary lifting forks with 30" (760 mm) lift

SP 3500 – High Speed Lift

- High speed lift/lower
- High speed lifting is automatically cut out when forks are 12" (305 mm) from max. elevation
- High speed lowering is automatically cut out when forks are 19.7" (500 mm) from the floor

Optional Equipment

1. Crown wire guidance (broadband technology) operates on all frequencies ranging from 5.2 to 10 kHz without changing components
2. End of aisle control system (wire or rail guidance required)
3. Aisle guide wheels for rail guidance
4. Enhanced steer wheel position indicator
5. Battery retainer interlock switch
6. LED work lights, LED dome lights and two-speed fans
7. Additional operator fan
8. Spotlights - LED or Halogen
9. Audible travel alarm
10. Zone Select key switch
11. Freezer conditioning
12. Custom outside straddle width in 1" (25 mm) increments from 45" to 72" (1145 mm to 1830 mm) (cannot be less than standard outside straddle width [20](#))
13. 42, 48, 54, 60 and 64" (1070, 1220, 1370, 1525 and 1625 mm) wide operator platforms (max. 12" [305 mm] greater than outside straddle width [20](#))
14. Power source for accessories
15. Wire mesh screen (standard with freezer conditioning)
16. Work Assist™ Accessories
 - Storage Bin
 - Clip pad and hook
 - Plate
 - Pocket
 - Clamp
17. Poly or Vulkollan non-marking drive tire
18. Vulkollan load wheels
19. Load-facing operator controls
20. InfoLink® Ready

Human Factor

The operator area is designed for maximum visibility and stability for increased operator confidence and comfort. The operator platform features a large window 7.5 ft.² (0.7 m²) for excellent visibility. A Crown designed clear-view mast gives the operator one forward and two peripheral windows for maximum visibility when the platform is lowered. The full free lift mast provides unobstructed visibility through the window when raised.

A low-profile power unit, low placement of the lower cross brace, and an outer C-channel rail assembly also contribute to excellent visibility.

A soft urethane twist grip is solidly mounted to the truck console to provide excellent stability for the operator during travel, plugging and braking. Controls for raise/lower, horn and emergency disconnect are conveniently located for efficient operation and minimal operator fatigue.

The steering wheel is angled at 10° and recessed to maximize the work area and reduce steer effort. The steering wheel and spinner knob are covered with soft urethane to reduce grip force and insulate against vibration. Control location keeps the operator's posture neutral at all times.

The anti-fatigue floor mat, made of a microcellular composition, absorbs shock and vibration. The brake pedal has a low-profile design and is flush with the floor mat when depressed. Heavy-duty side gates, with two horizontal and one vertical support rail, communicate security to the operator. For additional safety, cut-out switches disengage truck operation when gates are raised. Two work lights, two dome lights and a two-speed fan are optional. Power-on key prevents unauthorized operation of the truck; start position initializes truck self-test. The information display panel provides concise, clear feedback for the operator during truck operation.

Access 1 2 3®

The Access 1 2 3 Comprehensive System Control is a modular communications and control system. It monitors all on-board sensors, makes decisions based on the sensor readings, and subsequently, controls all system movements safely and smoothly. All five modules are in constant communication with each other via a CAN (Control Area Network) bus so that real-time information is accessible to the system at all times.

- Interactive Display Module
- Traction Control Module
- Vehicle Control Module
- Steering Control Module
- Guidance Control Module (optional)

The display module provides concise, clear feedback for the operator. The display includes a full featured on-board service tool so service technicians can actively view inputs and outputs during truck operation. No laptop or service terminal is required.

Truck performance specifications (maximum travel speed, coast, plugging, acceleration, travel speed at height, and low speed lowering) are adjustable using Access 1 2 3. This enables customizing truck performance to meet specific application or operator requirements.

Drive System

Crown has applied the latest generation AC drive system, enhanced with Access 1 2 3 technology. A Crown manufactured drive unit uses spiral bevel and helical gears from motor to drive wheel axle.

Fixed, mounted drive motor does not rotate minimizing wear on electrical cables.

Crown's AC Drive system dramatically improves travel speeds, acceleration and deceleration, thus increasing productivity.

The standard linear speed control provides smooth travel speed transition as lift heights change and increases productivity.

Intelligent Braking System (IBS)

Crown's patented Intelligent Braking System combines motor braking with optimum amounts of friction braking. The appropriate level of braking is applied dependent upon platform height, direction of travel, and truck weight. Braking force is automatically reduced as height increases and speed decreases.

Optimum braking for the right elevation gives operators more confidence and better control, while eliminating abrupt stops and reducing platform sway. Braking can also be accomplished by proportional plugging which permits the operator to control the rate of deceleration when extended stopping distance is preferred.

Steering

Standard on the SP 3500 Series is electronic steering that is microprocessor based. Steering wheel rotation provides smooth, operator feedback. Steer effort is minimal, lock to lock is 4.5 turns. Drive wheel rotates a full 180° for maximum maneuverability. Auto centering drive tire for trucks equipped with rail guidance.

Hydraulics

Heavy-duty motors and gear pumps are assembled into an integral unit. Crown-manufactured solenoid type manifolds with built-in check and relief valves. Two-speed lowering with proportional soft-start is standard on all models. Low-speed lowering is adjustable. Soft-start lowering feature reduces the harshness at the beginning and end of the lowering cycle. Maximum lowering speed is regulated by a pressure compensating flow control valve.

Velocity fuses are used in all cylinders to stop lowering should the speed exceed a preset value due to a line rupture. A hydraulic accumulator is used to cushion raise and lower functions. Manual lowering control allows lowering of platform from ground level. Oil reservoir is designed with a 100 mesh screen at the fill location, a suction strainer, spin-on type 10 micron return line filter and a magnetic drain plug.

Mast Assembly

High visibility two- and three-stage masts feature nested rail design with lift cylinders positioned behind mast rails. Three-stage mast has a low center cylinder for free lift. Routing of hoses and cables optimizes visibility through mast. Built-in sensors detect chain slack and shut down primary lower function. Exclusive staging bumpers virtually eliminate platform impact as the mast stages. Negative rail drop allows shimming of mast rollers without major disassembly.

Power Unit

Power unit is fabricated from heavy-gauge steel. Lower skirt is 9" (230 mm) high and 0.8" (20 mm) thick for component protection. Rugged steel doors suspended on heavy-duty hinges protect power unit components. Doors swing wide or can be lifted off for unrestricted service access. Battery side covers are all steel. An optional battery retainer interlock switch is available. Top battery cover allows access for service.

Wheels and Tires

Polyurethane drive tire is 13" (330 mm) diameter x 5.5" (140 mm) wide with 7.9" (200 mm) hub diameter. Tandem polyurethane load wheels are 5.9" (150 mm) diameter x 2.8" (70 mm) wide (4.3" [110 mm] wide for lift heights above 346" [8.8 m]). Optional polyurethane aisle guide wheels are 2" (50 mm) wide with a 9" or 2.6" (100 or 65 mm) diameter.

Forks

1.6" or 2" (40 or 50 mm) thick x 3.9" (100 mm) wide forged steel with Fork Tip Indicators. Standard length is 36" (915 mm). Optional lengths available.

Safety Shield

Safety glass to protect operator from chains and moving parts while in his normal operating position. Optional wire mesh shield (standard on freezer conditioning).

Warning Device Options

Audible or Visual Alerts

Safety considerations and dangers associated with audible travel alarms and lights include:

- Multiple alarms and/or lights can cause confusion.
- Workers ignore the alarms and/or lights after day-in and day-out exposure.
- Operator may transfer the responsibility for "looking out" to the pedestrians.
- Annoys operators and pedestrians.

Other Options Available

Contact your local Crown dealer.

Dimensions and performance data given may vary due to manufacturing tolerances. Performance is based on an average size vehicle and is affected by weight, condition of truck, how it is equipped and the conditions of the operating area. Crown products and specifications are subject to change without notice.



crown.com

You can count on Crown to build lift trucks designed for safe operation, but that's only part of the safety equation. Crown encourages safe operating practices through ongoing operator training, safety-focused supervision, maintenance and a safe working environment. Go to crown.com and view our safety section to learn more.

Because Crown is continually improving its products, specifications are subject to change without notice.

Crown, the Crown logo, the color beige, the Momentum symbol, Work Assist, Access 1 2 3, InfoLink and InfoPoint are trademarks of Crown Equipment Corporation. Other trademarks are property of their owners.

Copyright 2017-2023 Crown Equipment Corporation
SF19610 Rev.08-23
Printed in U.S.A.