

CROWN

SHR 5500 SERIES

Specifications

Reach Stacker



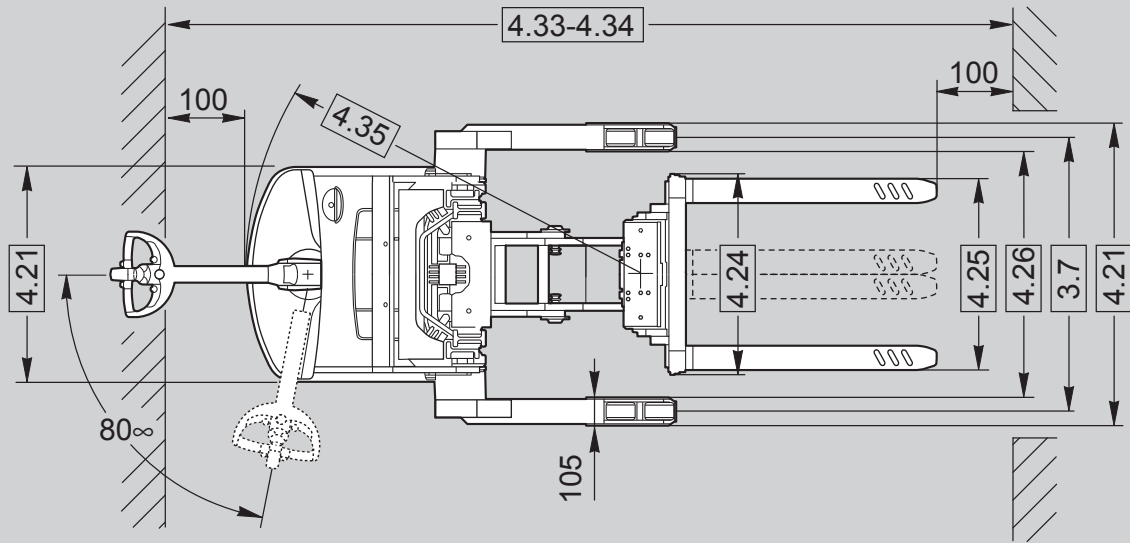

Optional Loadwheels

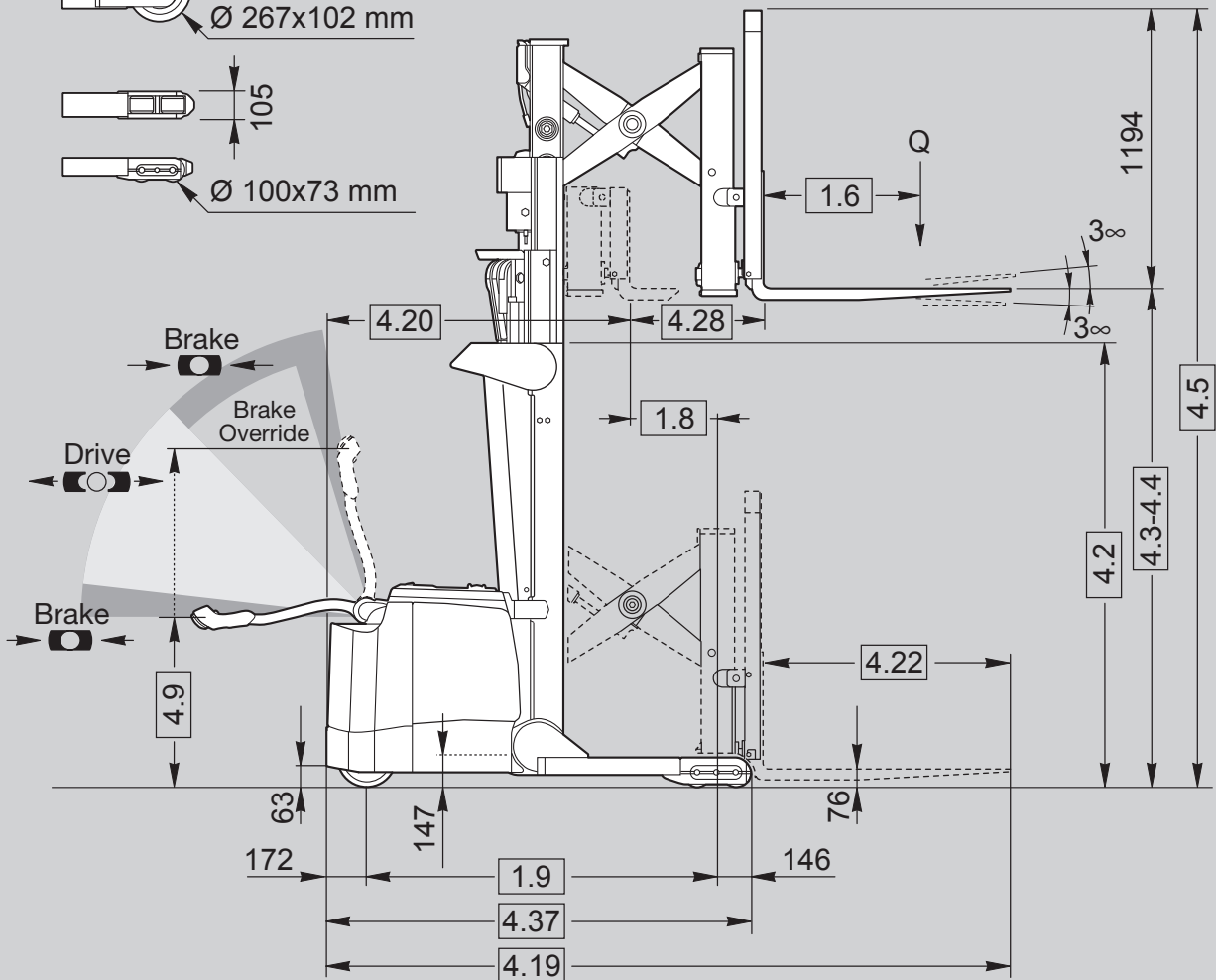
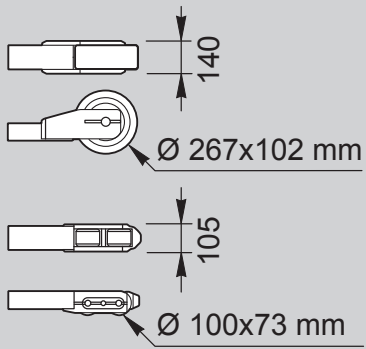

General Information	1.1	Manufacturer	Crown Equipment Corporation										
	1.2	Model				SHR 5520-1.1	SHR 5520-1.35	SHR 5540-1.6					
	1.3	Power	electric										
	1.4	Operator Type	pedestrian										
	1.5	Load Capacity		Q	t	1.1	1.35	1.6					
	1.6	Load Centre		c	mm	600							
	1.8	Load Distance		x	mm	392							
	1.9	Wheel Base		y	mm	1339					1504		
	Weights	2.1	Weight	less battery		kg	see table 1						
2.2		Axle Load	w. load, front / rear		kg	see table 1							
2.3		Axle Load	w.o. load, front / rear		kg	see table 1							
Tyres	3.1	Tyre Type	Vulkollan / PU										
	3.2	Wheel Size	front		mm	Ø 250 x 75							
	3.3	Wheel Size	rear		mm	Ø 127 x 73							
	3.5	Wheels	number (x=driven) front/rear			1x / 4							
	3.6	Track Width	front	b10	mm	central position							
	3.7	Track Width *	rear	b11	mm	965 - 1372							
	Dimensions	4.1	Fork Carriage Tilt	forwards/backwards	°	angle	3 / 3						
4.2		Mast	collapsed height	h1	mm	see table 1							
4.3		Free Lift		h2	mm	see table 1							
4.4		Lift Height		h3	mm	see table 1							
4.5		Mast	extended height	h4	mm	see table 1							
4.9		Tiller Arm Height	in drive position min./max.	h14	mm	800 - 1278							
4.15		Fork Height	lowered	h13	mm	76							
4.19		Overall Length	retracted	l1	mm	2263					2428		
4.20		Headlength		l2	mm	1118					1283		
4.21		Overall Width **	front / rear	b1/b2	mm	915 / 1074 - 1480							
4.22		Fork Dimension	standard	thxwxl	mm	40 x 100 x 1145					45 x 100 x 1145		
			optional length	l	mm	760, 915, 990, 1065, 1220, 1370, 1525							
4.23		Fork Carriage	ISO class			2A							
4.24		Fork Carriage Width		b3	mm	813							
4.25		Width Across Forks		b5	mm	200 - 815							
4.26		Inside Straddle Width	in 51 mm increments	b4	mm	863 - 1271							
4.28		Reach		l4	mm	590							
4.31		Ground Clearance***	with load, below mast	m1	mm	53							
4.32		Ground Clearance***	centre of wheelbase	m2	mm	53							
4.33		Working Aisle Width	1000 x 1200 mm traverse	Ast	mm	2564					2728		
4.34	Working Aisle Width	800 x 1200 mm length	Ast	mm	2612					2776			
4.35	Turning Radius		Wa	mm	1510					1674			
4.37	Length Over Outriggers****		l7	mm	1656					1821			
Performance	5.1	Travel Speed	w. / w.o. load		km/h	5.8 / 6							
	5.2	Lift Speed	w. / w.o. load		m/s	0.15 / 0.24							
	5.3	Lowering Speed	w. / w.o. load		m/s	0.25 / 0.25							
	5.7	Gradeability	w. / w.o. load, 30 min. rating		%	5 / 9	4 / 8	4 / 8					
	5.8	Max. Gradeability	w. / w.o. load, 5 min. rating		%	10 / 10							
	5.10	Service Brake				electromagnetic							
Motors	6.1	Traction Motor	rating at S2 60 min.		kW	2.0							
	6.2	Lift Motor	rating at S3 15%		kW	3.3							
	6.3	Max. Battery Box Size		lxwxh	mm	168 x 778 x 622					333 x 835 x 622		
	6.4	Battery Voltage	nominal capacity K5		V / Ah	24 / 258					24 / 625		
	6.5	Battery Weight	min/max		kg	230 / 320					440 / 635		
8.1	Type Controller	drive			transistor								

* Add 45 mm with optional load wheels Ø 267x102 mm

** Add 76 mm with optional load wheels Ø 267x102 mm

*** With optional tandem load wheels Ø 100x73 mm, -28 mm

**** Subtract 28 mm with optional load wheels Ø 100x73 mm and 12 mm with optional load wheels Ø 267x102 mm

Table 1					SHR 5520-1.1			SHR 5520-1.35			SHR 5540-1.6			
					TL		TT	TL		TT	TL		TT	
2.1	Weight	less battery		kg	1699	1746	1873	1932	1980	2107	1826	1873	2000	2186
2.2	Axle Load	with load, front		kg	980	995	1102	1112	1127	1247	1126	1141	1252	1270
		with load, rear		kg	2084	2117	2155	2412	2445	2483	2748	2781	2819	2976
2.3	Axle Load	w.o. load, front		kg	1188	1217	1288	1369	1399	1472	1383	1413	1483	1563
		w.o. load, rear		kg	742	761	816	795	812	866	885	903	959	1066
4.2	Mast	collapsed height	h1	mm	2121	2426	1905	2121	2426	1905	2121	2426	1905	2261
4.3	Free Lift		h2	mm	152	152	711	152	152	711	152	152	711	1067
4.4	Lift Height		h3	mm	3225	3810	3960	3225	3810	3960	3225	3810	3960	4875*
4.5	Mast	extended height	h4	mm	4419	5004	5154	4419	5004	5154	4419	5004	5154	6069

* Minimum inside straddle width is 1067 mm

Standard Equipment

1. 24-volt electrical system
2. Crown's Access 1 2 3® Comprehensive System Control
3. Crown's Access 1 2 3® information display
 - 1 line display with 8 characters
 - Scrolling function via 5 button access
 - Three selectable performance levels
 - BDI with lift interrupt
 - Event codes
 - Access 1 2 3® onboard diagnostics with real time troubleshooting capability
 - PIN code capability
4. AC traction and steer motors
5. Performance enhancing features
 - X10® Handle
 - Brake override
 - Electronic power steering
 - Ramp hold and speed control
 - Power boost
 - High-visibility mast and carriage
 - Low profile power unit
 - Tool storage tray
6. Plexiglass mast guard
7. Vulkollan drive tyre Ø 250 x 75 mm
8. Polyurethane tandem load wheels Ø 127 x 73 mm
9. InfoPoint® System
10. Steel power unit covers
11. Load backrest
12. Emergency power disconnect plug
13. Key switch
14. Horn
15. SBE 160 red battery connector
16. Reversing button
17. Electric park brake
18. Fork tip indicators
19. Battery compartment rollers

Optional Equipment

1. 30 amp on-board charger only for the small battery compartment
2. Work Assist™ Accessories:
 - Clip pad
 - Hook
 - Clip pad and hook
 - Pocket
3. Sideshifter
4. Optional fork lengths
5. Freezer conditioning
6. Metal mast grill

7. Ø 254 x 100 mm drive tyre
 - Soft poly
 - Siped soft poly
8. Polyurethane load wheels
 - tandem Ø 100 x 73 mm
 - single Ø 267 x 102 mm
9. Travel Alarm
10. Flashing amber light or mast mounted spotlight
11. Special paint

Operator Controls

Crown's robust X10 handle places all control buttons in the optimum position for ease of operation with either hand and to minimise hand and wrist movements. An ergonomic forward/reverse thumb wheel allows for precise manoeuvring. The control hand grips are urethane covered for insulation from cold and vibration with integrated horn buttons for easy activation. The handle contains a safety button which reverses the direction of the truck should the button touch the operator.

A rabbit/turtle switch incorporates two levels of programmable travel performance so operators can select the setting that matches their experience level or application requirements. Exclusive brake override feature allows slow speed travel with the handle near vertical. This feature improves manoeuvrability in tight areas.

Performance

The SHR 5500 Series incorporates the latest generation AC drive system enhanced with Access 1 2 3 technology. Crown's Access 1 2 3 technology continuously monitors truck systems and adjusts system parameters to deliver optimum performance and control. The Access Display provides a convenient interface for operators keeping them informed of any changes impacting truck performance and allowing them to choose from three performance profiles when enabled.

Programmable performance settings enable authorised personnel to tune the lift truck to different operator skill levels, or to meet specific application requirements. In addition, up to 25 PIN codes can be assigned

to individual operators and matched to one of the pre-programmed performance profiles if desired. Electronic power steering allows the operator to manoeuvre heavy loads in tight spaces throughout the day while minimising fatigue. The ramp hold feature uses the motor to prevent truck movement when the brake is released and no travel command is present. The ramp speed control feature ensures that actual travel speed matches requested travel speed.

Electrical System

A heavy-duty 24-volt fused electrical system utilises microprocessor controls for maximum energy efficiency, reduced maintenance and infinite speed control capability. Access control modules for travel, lift and steer are sealed from dirt, dust and moisture for trouble-free operation.

Hydraulic System

Heavy-duty hydraulic motor (3.3 kW) is transistor controlled and matched with a gear type pump selected for optimum lift performance and low noise. Single-speed lift with programmable acceleration - deceleration and programmable two-speed lowering enables customisation to match operator preference or application requirements. Cylinder rods are hard-plated chrome with polyurethane seals. Relief valve, tuned to capacity, protects all components in the hydraulic system. Reservoir incorporates an in-tank 10 micron return filter for removing debris from oil.

Drive Unit / Brake

Heavy-duty gearbox with helical spur input gear for quiet operation. Regenerative motor braking is activated under a downhill condition, during plugging or when the directional control is returned to neutral. An electro-magnetic brake, spring applied and electrically released, is mounted on top of the drive motor.

The electro-magnetic brake serves as the parking brake and applies when the control handle position moves from the operating zone to brake zone during truck operation.

Power Steering

Electronic power steering is provided by a heavy-duty AC motor that pivots the drive unit when steer tiller movement is detected.

Mast

High visibility two and three-stage mast design with angled cross bracing and lift cylinders located behind nested I-beams provides maximum visibility for load positioning and placement. Crown's staging cushions coupled with lowering dampers ensure smooth operation. Rolled steel outer mast channels and inner I-beams roll on canted, steel, anti-friction roller bearings for minimal current draw and long life. Mast and chain rollers are sealed and lubricated for life.

Reach Mechanism

An exclusive reach mechanism design provides unmatched visibility at all rack levels.

Serviceability / Durability

The Access display simplifies service by providing advanced diagnostics without the need for separate handsets. The display allows the service engineers to view event service codes and truck hours when event occurred, perform system calibrations or functional tests of components, and make necessary adjustments. Crown's InfoPoint System compliments Access 1 2 3 diagnostics by providing on-truck component maps to further simplify troubleshooting. Removable steel power unit doors are hinged for ease of opening providing excellent accessibility to the distribution panel and all other components. Battery removal can be accomplished from either side. Battery compartment rollers are standard.

Safety Regulations

Conforms to European safety standards. Dimensions and performance data given may vary due to manufacturing tolerances. Performance is based on an average size vehicle and is affected by weight, condition of truck, how it is equipped and the conditions of the operating area. Crown products and specifications are subject to change without notice.