

CROWN

PR 4500 SERIES

Profile Sheet
Rider Pallet Truck



PR 4500 Series

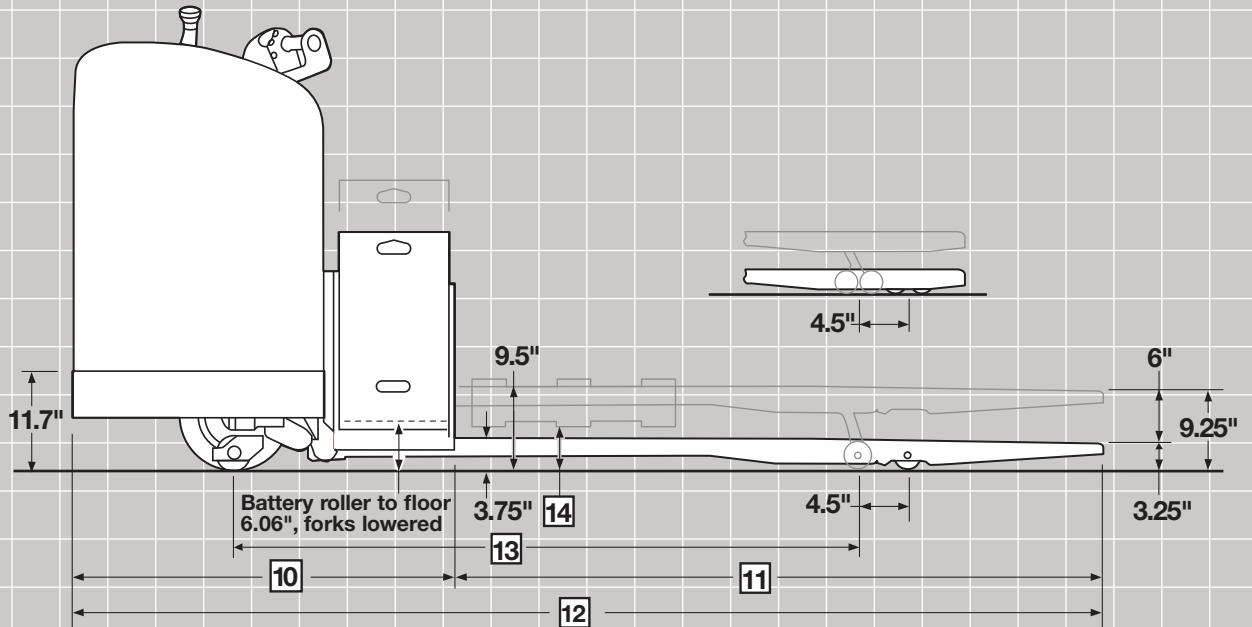
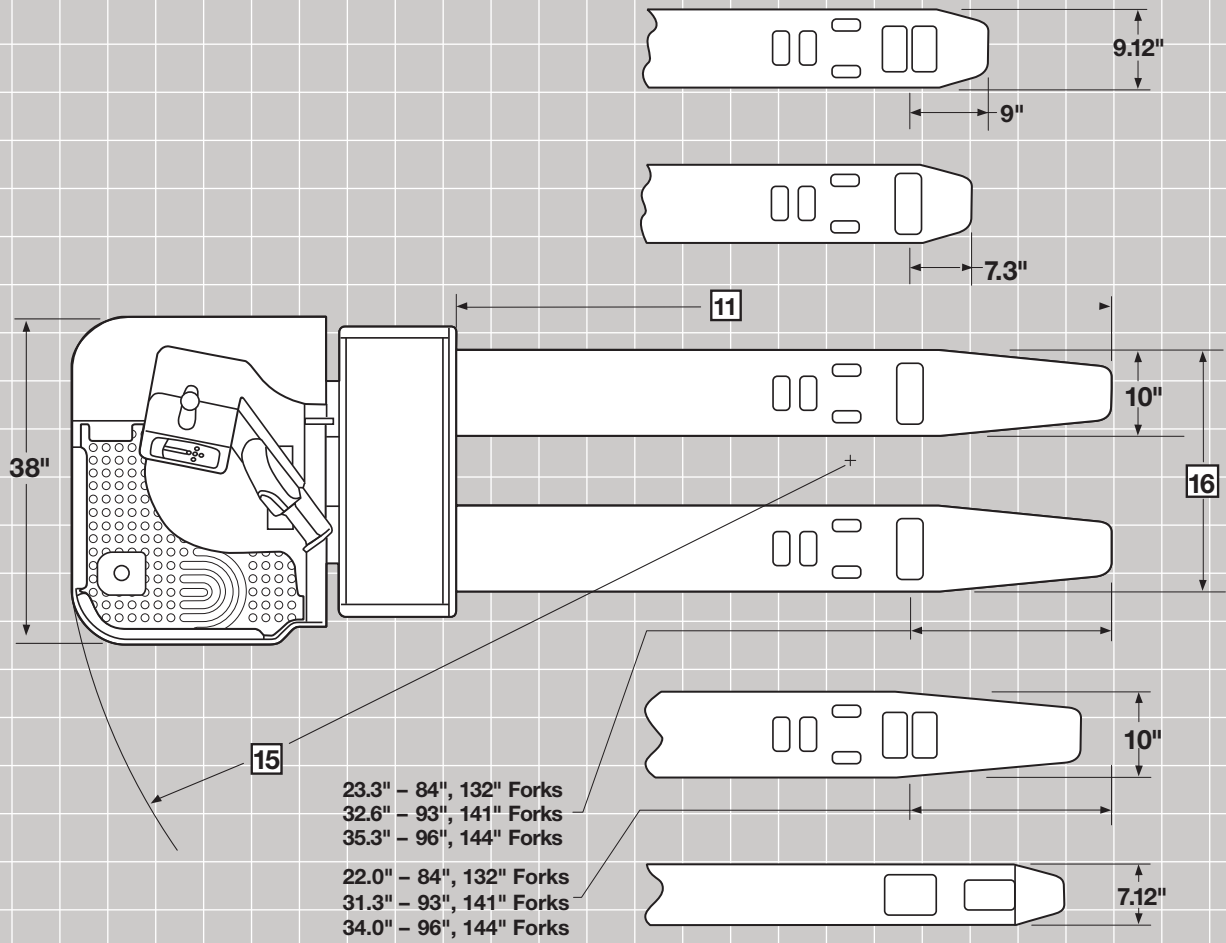

PR 4500 Series

General Info	1	Manufacturer		Crown Equipment	
	2	Model		PR 4500	
	3	Load Capacity	lb	6000/8000	
	4	Power	Electric	24 Volts	
	5	Operator Type	Stand-up	Rider	
Dimensions	8	Lift Height	in	9.25	
	9	Lift	in	6"	
	10	Head Length		44.7	
	16	Outside Fork Spread	Standard Tip	in	22/27
			Extended Tip	in	23/28
Batteries		Min/Max Weight	lb	975/1500	
		Max Amp	amp	750	
		Max Battery Size W x L x H	in	13.19 x 31.12 x 31.62	

PR 4500 Series			Standard-Tip Forks						
Forks		Nominal Fork Length	in	36	42	48	54	60	96
	11	Actual Fork Length	in	35.75	41.75	47.75	53.75	59.75	95.75
	12	Overall Length	in	80.50	86.50	92.50	98.50	104.50	140.50
	13	Wheelbase - Forks Raised	in	52.44	58.44	64.44	70.44	76.44	112.44
	14	Grade Clearance - Forks Raised	%	31	28	26	24	22	15
	15	Turning Radius - Forks Raised	in	74.44	80.44	86.44	92.44	98.44	134.44
	7	Truck Weight w/o battery	6000 lb	lb	1738	1754	1830	1846	1862
	8000 lb		lb	1757	1781	1865	1889	1913	2077

PR 4500 Series			Extended-Tip Forks						
Forks		Nominal Fork Length	in	84	93	96	132	141	144**
	11	Actual Fork Length	in	83.70	93	95.75	131.75	140.75	143.75
	12	Overall Length	in	128.50	137.75	140.50	176.50	185.50	188.50
	13	Wheelbase - Forks Raised	in	87.44	87.44	87.44	135.44	135.44	135.44
	14	Grade Clearance - Forks Raised	%	20	20	20	16	16	16
	15	Turning Radius - Forks Raised	in	106.12	106.12	106.12	154.12	154.12	154.12
	7	Truck Weight w/o battery	6000 lb	lb	1944	2025	2040	2457	2538
	8000 lb		lb	2004	2085	2100			

** Configuration available with shorter wheelbase and turning radius

Wheels and Tires	Model	PR 4500-60/80		
	Drive Tire	in	13 x 4.5 x 8 (p)	
	Casters	in	2 - 4 x 2.5 (p)	
	Load Wheels			2 - 3.25 x 6.5 (-302)
		-301		Moderate cut/tear resistance, high capacity. High capacity transport. Not for dock use.
-302			Highest cut/tear resistance offered. Extremely high capacity, low rolling resistance. Docks, rough floors and floor debris.	
-401			Combines good cut/tear resistance and very high capacity. Use where nothing else works.	

(p) = poly



Crown Equipment Corporation

New Bremen, Ohio 45869 USA

Tel 419-629-2311

Fax 419-629-3796

crown.com

You can count on Crown to build lift trucks designed for safe operation, but that's only part of the safety equation. Crown encourages safe operating practices through ongoing operator training, safety-focused supervision, maintenance and a safe working environment. Go to crown.com and view our safety section to learn more.

Because Crown is continually improving its products, specifications are subject to change without notice.

Crown, the Crown logo, the color beige, the Momentum symbol, Access 1 2 3, InfoLink, InfoPoint, e-GEN, and Work Assist are trademarks of Crown Equipment Corporation.

Copyright 2012 Crown Equipment Corporation
SF18476 01/12
Printed in U.S.A.