



# FC 4500 SERIES

## Profile Sheet

Sit-Down Rider Lift Truck



# FC 4500 Series

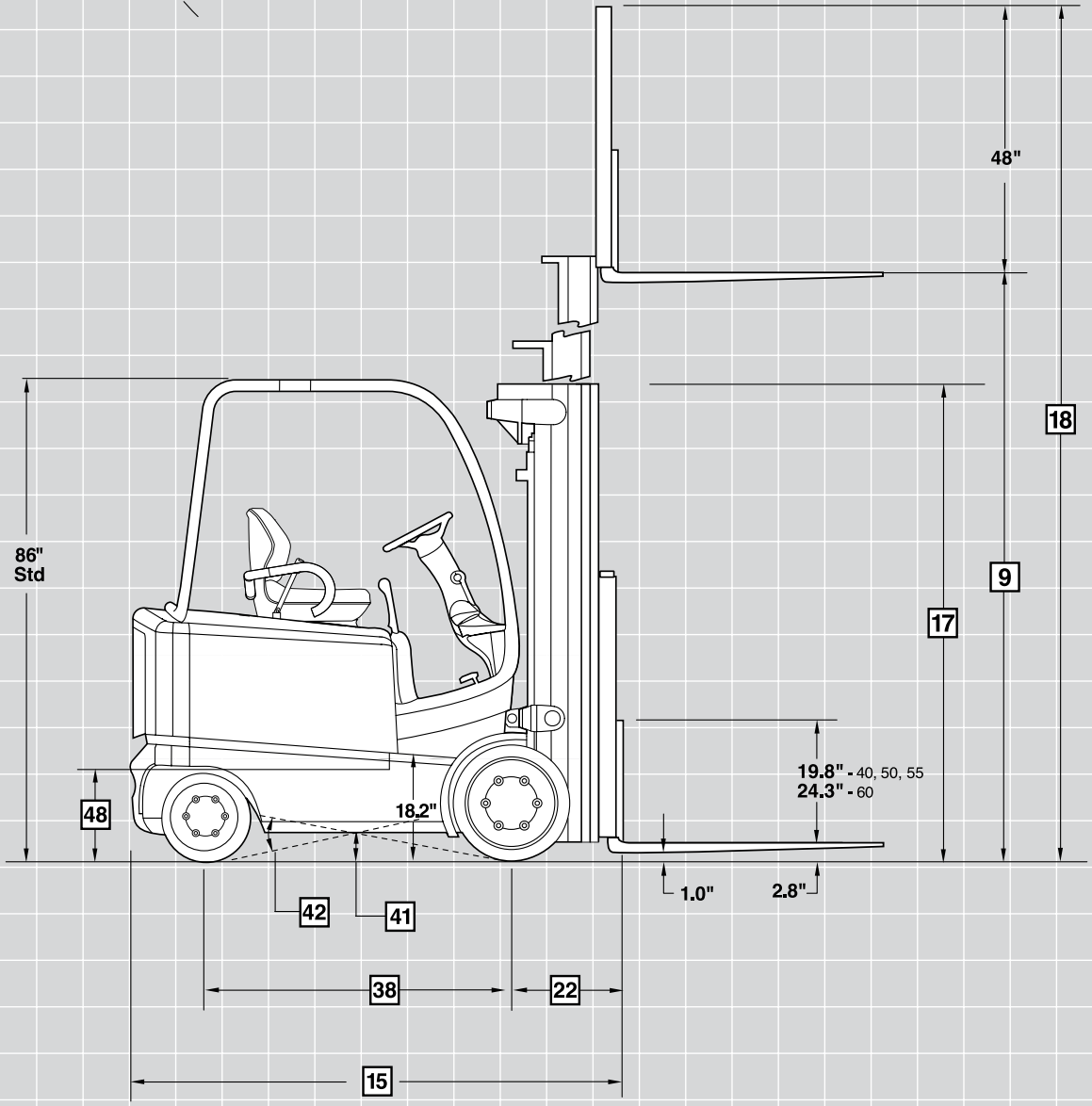
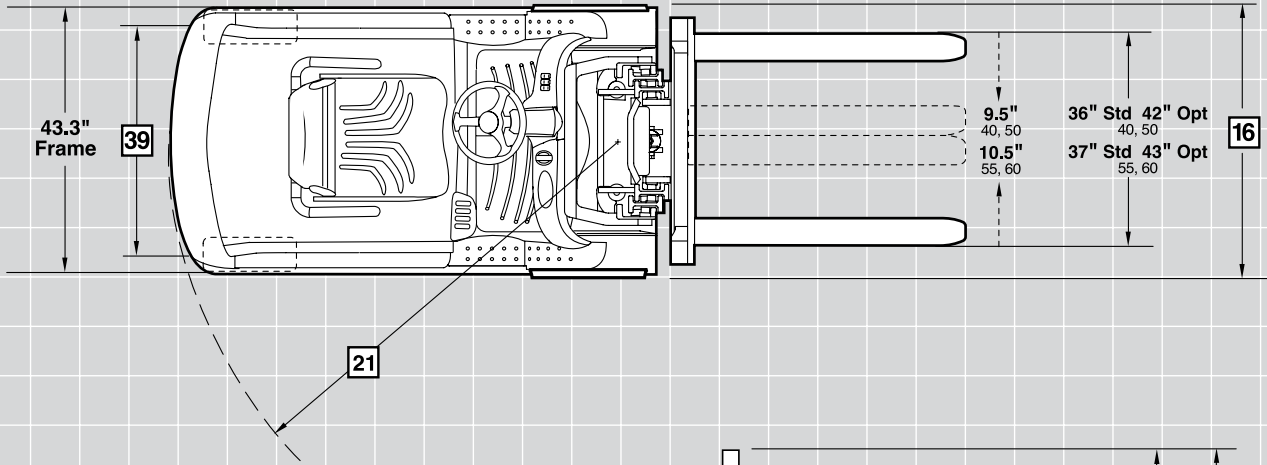

# FC 4500 Series

				Crown Equipment Corporation		
				FC 4510/15-40	FC 4520/25-40	
General Information	1	<b>Manufacturer</b>		Crown Equipment Corporation		
	2	<b>Model</b>		FC 4510/15-40	FC 4520/25-40	
	3	<b>Load Capacity*</b>	lb	4000		
	4	<b>Load Center</b>	Fork Face to Load CG	in	24	
	5	<b>Power</b>	Electric	36-Volt / 48-Volt		
	6	<b>Operator Type</b>	Sit-down Rider Counterbalanced			
	7	<b>Tire Type</b>	Cushion			
	8	<b>Wheels (x = driven)</b>	Number Front/Rear	2x / 2		
Dimensions	9	<b>Mast (See Mast Chart)</b>	Lifting Height (MFH)	in	188	
			Free Lift Height	in	32.2	
	12	<b>Fork Carriage</b>	ITA Class II			
	13	<b>Forks</b>	Standard L x W x T	in	36 x 4 x 1.8	
			Optional Lengths	in	42, 48, 54, 60	
	14	<b>Tilt</b>	F° / B°	degree	5 / 5	
			Interlocked Fork Height**	in	66	
		<b>Battery Compartment</b>		in	27	33
	15	<b>Headlength</b>	Length to Fork Face	in	77.8	84
	16	<b>Width Overall</b>	Standard Tread	in	43.4	
			Wide Tread	in	47.5	
	17	<b>Height with Load Backrest</b>	Mast Collapsed	in	83	
			Mast Extended	in	236	
	21	<b>Turning Radius</b>		in	69.1	75.3
22	<b>Load Distance</b>	Center of Wheel to Fork Face	in	15.8		
23	<b>Aisle Width (Add Load + Clear)</b>	Right Angle Stack	in	84.9	91.1	
Chassis	36	<b>Tires</b>	Size Front	in	21 x 7 x 15	
			Size Rear	in	16 x 6 x 10.5	
	38	<b>Wheelbase</b>		in	49.7	54.7
	39	<b>Tread/Track Width</b>	Front Standard / Rear	in	36.4 / 36	
			Front Optional / Rear	in	40.5 / 36	
	40	<b>Ground Clearance, Loaded</b>	Lowest Point	in	3	
	41		Center of Wheelbase	in	4.8	
	42	<b>Grade Clearance, Loaded</b>		%	38	35
43	<b>Brakes</b>	Service	Foot Hydraulic			
		Parking	Hand Electro-hydraulic			
Battery	45	<b>Battery††</b>	Type	Lead Acid		
	46		Capacity - 36V	AH	1210	1430
				kWh	42.5	50.2
	47		Capacity - 48V	AH	880	1100
				kWh	41.2	51.5
			Weight - Min	lb	2630	2800
			Weight - Max	lb	3200	4000
			Size - Max	Length	27.25	32.94
				Width	38.69	
				Height	22.25	
48	<b>Battery Floor Height</b>	With Rollers / w/o Rollers	in	17.4 / 17.1		

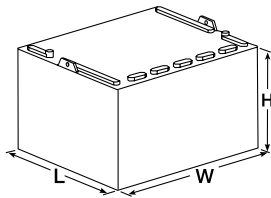

\* Optional masts, attachments, longer load dimensions and higher lifting heights may result in derating of the capacity. Contact local dealer.

\*\* Forward tilt restricted to 2° above this height.

† Based on TT mast.

†† With maintenance-free batteries or batteries with a lid (flat top), consult factory.

# FC 4500 Series

		Crown Equipment Corporation				
		FC 4510/15-50	FC 4520/25-50	FC 4540/45-50		
General Information	1	<b>Manufacturer</b>	Crown Equipment Corporation			
	2	<b>Model</b>	FC 4510/15-50	FC 4520/25-50	FC 4540/45-50	
	3	<b>Load Capacity*</b>		5000		
	4	<b>Load Center</b>	Fork Face to Load CG	24		
	5	<b>Power</b>	Electric	36-Volt / 48-Volt		
	6	<b>Operator Type</b>		Sit-down Rider Counterbalanced		
	7	<b>Tire Type</b>		Cushion		
	8	<b>Wheels (x = driven)</b>	Number Front/Rear	2x / 2		
Dimensions	9	<b>Mast (See Mast Chart)</b>	Lifting Height (MFH)	188		
			Free Lift Height	32.2		
	12	<b>Fork Carriage</b>	ITA Class II			
	13	<b>Forks</b>	Standard L x W x T	36 x 4 x 1.8		
			Optional Lengths	42, 48, 54, 60		
	14	<b>Tilt</b>	F° / B°	5 / 5		
			Interlocked Fork Height**	66		
		<b>Battery Compartment</b>		27	33	36
	15	<b>Headlength</b>	Length to Fork Face	81.2	84	87.1
	16	<b>Width Overall</b>	Standard Tread	43.4		
			Wide Tread	47.5		
	17	<b>Height with Load Backrest</b>	Mast Collapsed	83		
			Mast Extended	236		
	21	<b>Turning Radius</b>		71.9	75.4	78.0
22	<b>Load Distance</b>	Center of Wheel to Fork Face	15.8			
23	<b>Aisle Width (Add Load + Clear)</b>	Right Angle Stack	87.7	91.2	93.8	
Chassis	36	<b>Tires</b>	Size Front	21 x 8 x 15		
	37		Size Rear	16 x 6 x 10.5		
	38	<b>Wheelbase</b>		49.7	54.7	54.7
	39	<b>Tread/Track Width</b>	Front Standard / Rear	35.4 / 36		
			Front Optional / Rear	39.5 / 36		
	40	<b>Ground Clearance, Loaded</b>	Lowest Point	3		
	41		Center of Wheelbase	4.8		
	42	<b>Grade Clearance, Loaded</b>		38	35	35
43	<b>Brakes</b>	Service	Foot Hydraulic			
		Parking	Hand Electro-hydraulic			
Battery	45	<b>Battery††</b>	Type	Lead Acid		
	46	Capacity - 36V	AH	1210	1430	1650
			kWh	42.5	50.2	57.9
	47	Capacity - 48V	AH	880	1100	1210
			kWh	41.2	51.5	56.6
		Weight - Min	lb	2630	2800	3100
		Weight - Max	lb	3200	4000	4250
		Size - Max	Length	27.25	32.94	36.38
			Width	38.69		
Height			22.25			
48	<b>Battery Floor Height</b>	With Rollers / w/o Rollers	17.4 / 17.1			

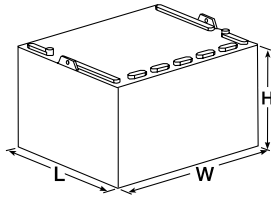

\* Optional masts, attachments, longer load dimensions and higher lifting heights may result in derating of the capacity. Contact local dealer.

\*\* Forward tilt restricted to 2° above this height.

† Based on TT mast.

†† With maintenance-free batteries or batteries with a lid (flat top), consult factory.

# FC 4500 Series

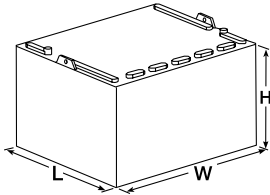
				Crown Equipment Corporation		
				FC 4520/25-55	FC 4540/45-55	
General Information	1	<b>Manufacturer</b>		Crown Equipment Corporation		
	2	<b>Model</b>		FC 4520/25-55	FC 4540/45-55	
	3	<b>Load Capacity*</b>	lb	5500		
	4	<b>Load Center</b>	Fork Face to Load CG	in	24	
	5	<b>Power</b>	Electric	36-Volt / 48-Volt		
	6	<b>Operator Type</b>		Sit-down Rider Counterbalanced		
	7	<b>Tire Type</b>		Cushion		
	8	<b>Wheels (x = driven)</b>	Number Front/Rear	2x / 2		
Dimensions	9	<b>Mast (See Mast Chart)</b>	Lifting Height (MFH)	in	188	
			Free Lift Height	in	32.2	
	12	<b>Fork Carriage</b>		ITA Class II		
	13	<b>Forks</b>	Standard L x W x T	in	36 x 5 x 1.8	
			Optional Lengths	in	42, 48, 54, 60	
	14	<b>Tilt</b>	F° / B°	degree	5 / 5	
			Interlocked Fork Height**	in	66	
		<b>Battery Compartment</b>		in	33	36
	15	<b>Headlength</b>	Length to Fork Face	in	87.4	90.5
	16	<b>Width Overall</b>	Standard Tread	in	45.2	
			Wide Tread	in	48	
	17	<b>Height with Load Backrest</b>	Mast Collapsed	in	83	
			Mast Extended	in	236	
21	<b>Turning Radius</b>		in	78.2	80.9	
22	<b>Load Distance</b>	Center of Wheel to Fork Face	in	15.8		
23	<b>Aisle Width (Add Load + Clear)</b>	Right Angle Stack	in	94.0	96.7	
Chassis	36	<b>Tires</b>	Size Front	in	21 x 9 x 15	
			Size Rear	in	16 x 7 x 10.5	
	38	<b>Wheelbase</b>		in	54.7	54.7
	39	<b>Tread/Track Width</b>	Front Standard / Rear	in	36.2 / 36	
			Front Optional / Rear	in	39 / 36	
	40	<b>Ground Clearance, Loaded</b>	Lowest Point	in	3	
	41	<b>Grade Clearance, Loaded</b>	Center of Wheelbase	in	4.8	
	42	<b>Grade Clearance, Loaded</b>		%	35	35
43	<b>Brakes</b>	Service		Foot Hydraulic		
		Parking		Hand Electro-hydraulic		
Battery	45	<b>Battery††</b>	Type	Lead Acid		
	46		Capacity - 36V	AH	1430	1650
				kWh	50.2	57.9
			Capacity - 48V	AH	1100	1210
				kWh	51.5	56.6
	47		Weight - Min	lb	2800	3100
			Weight - Max	lb	4000	4250
			Size - Max	Length	32.94	36.38
		Width	38.69			
		Height	22.25			
48	<b>Battery Floor Height</b>	With Rollers / w/o Rollers	in	17.4 / 17.1		

\* Optional masts, attachments, longer load dimensions and higher lifting heights may result in derating of the capacity. Contact local dealer.

\*\* Forward tilt restricted to 2° above this height.

† Based on TT mast.

†† With maintenance-free batteries or batteries with a lid (flat top), consult factory.

# FC 4500 Series

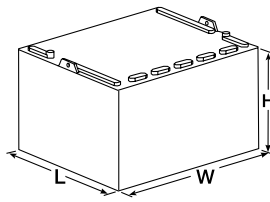
				Crown Equipment Corporation		
				FC 4520/25-60	FC 4540/45-60	
General Information	1	<b>Manufacturer</b>		Crown Equipment Corporation		
	2	<b>Model</b>		FC 4520/25-60	FC 4540/45-60	
	3	<b>Load Capacity*</b>		6000		
	4	<b>Load Center</b>	Fork Face to Load CG	in	24	
	5	<b>Power</b>	Electric		36-Volt / 48-Volt	
	6	<b>Operator Type</b>			Sit-down Rider Counterbalanced	
	7	<b>Tire Type</b>			Cushion	
	8	<b>Wheels (x = driven)</b>	Number Front/Rear		2x / 2	
Dimensions	9	<b>Mast (See Mast Chart)</b>	Lifting Height (MFH)	in	180	
			Free Lift Height	in	32.2	
	12	<b>Fork Carriage</b>			ITA Class III	
	13	<b>Forks</b>	Standard L x W x T	in	36 x 5 x 1.8	
			Optional Lengths	in	42, 48, 54, 60	
	14	<b>Tilt</b>	F° / B°	degree	5 / 5	
			Interlocked Fork Height**	in	66	
		<b>Battery Compartment</b>		in	33	36
	15	<b>Headlength</b>	Length to Fork Face	in	87.7	90.8
	16	<b>Width Overall</b>	Standard Tread	in	45	
			Wide Tread	in	48	
	17	<b>Height with Load Backrest</b>	Mast Collapsed	in	83	
			Mast Extended	in	228	
21	<b>Turning Radius</b>		in	78.2	80.9	
22	<b>Load Distance</b>	Center of Wheel to Fork Face	in	16.1		
23	<b>Aisle Width (Add Load + Clear)</b>	Right Angle Stack	in	94.3	97.0	
Chassis	36	<b>Tires</b>	Size Front	in	21 x 9 x 15	
	37		Size Rear	in	16 x 7 x 10.5	
	38	<b>Wheelbase</b>		in	54.7	54.7
	39	<b>Tread/Track Width</b>	Front Standard / Rear	in	36.2 / 36	
			Front Optional / Rear	in	39 / 36	
	40	<b>Ground Clearance, Loaded</b>	Lowest Point	in	3	
	41		Center of Wheelbase	in	4.8	
	42	<b>Grade Clearance, Loaded</b>		%	35	35
43	<b>Brakes</b>	Service		Foot Hydraulic		
		Parking		Hand Electro-hydraulic		
Battery	45	<b>Battery††</b>	Type		Lead Acid	
	46		Capacity - 36V	AH	1430	1650
				kWh	50.2	57.9
			Capacity - 48V	AH	1100	1210
				kWh	51.5	56.6
	47		Weight - Min	lb	2800	3100
			Weight - Max	lb	4000	4250
			Size - Max	Length	32.94	36.38
			Width		38.69	
			Height		22.25	
48	<b>Battery Floor Height</b>	With Rollers / w/o Rollers	in	17.4 / 17.1		

\* Optional masts, attachments, longer load dimensions and higher lifting heights may result in derating of the capacity. Contact local dealer.

\*\* Forward tilt restricted to 2° above this height.

† Based on TT mast.

†† With maintenance-free batteries or batteries with a lid (flat top), consult factory.

## FC 4500 Series

Mast Chart FC 4500-40/50/55			TL			TT								QUAD				
9	Lifting Height	in	126	138	150	188	206	216*	231*	246*	258*	276*	291*	240*	258*	276*	294*	312*
11	Free Lift Height†	in	5.6	5.6	5.6	32.2	38.2	44.2	50.2	56.2	62.2	68.2	74.2	31.8	39.8	43.8	49.8	55.8
14	Interlocked Fork Ht	in	78	78	78	66	72	78	84	90	96	102	108	76	82	88	94	100
17	Mast Collapsed Ht	in	83	89	95	83	89	95	101	107	113	119	125	83	89	95	101	107
18	Mast Extended Ht†	in	174	186	198	236	254	264	279	294	306	324	339	288	306	324	342	360

Mast Chart FC 4500-60			TL			TT					
9	Lifting Height	in	118	130	142	180	198	208*	223*	238*	250*
11	Free Lift Height†	in	5.9	5.9	5.9	32.2	38.2	44.2	50.2	56.2	62.2
14	Interlocked Fork Ht	in	78	78	78	66	72	78	84	90	96
17	Mast Collapsed Ht	in	83	89	95	83	89	95	101	107	113
18	Mast Extended Ht†	in	166	178	190	228	246	256	271	286	298

\* Wide tread drive tires recommended. Refer to capacity charts.  
 † Includes load backrest.



**Crown Equipment Corporation**  
 New Bremen, Ohio 45869 USA  
**Tel** 419-629-2311  
**Fax** 419-629-3796  
 crown.com

**You can count on Crown to build lift trucks designed for safe operation, but that's only part of the safety equation. Crown encourages safe operating practices through ongoing operator training, safety-focused supervision, maintenance and a safe working environment. Go to crown.com and view our safety section to learn more.**

Because Crown is continually improving its products, specifications are subject to change without notice.

Crown, the Crown logo, the color beige, the Momentum symbol, Access 1 2 3, InfoPoint, Intrinsic Stability System, FlexSeat, InfoLink and Work Assist are trademarks of Crown Equipment Corporation.

Copyright 2007-2011 Crown Equipment Corporation  
 SF18708 Rev. 3/11  
 Printed in U.S.A.