

CROWN



RC 5500 Series

Profile Sheet

RC 5500 Series

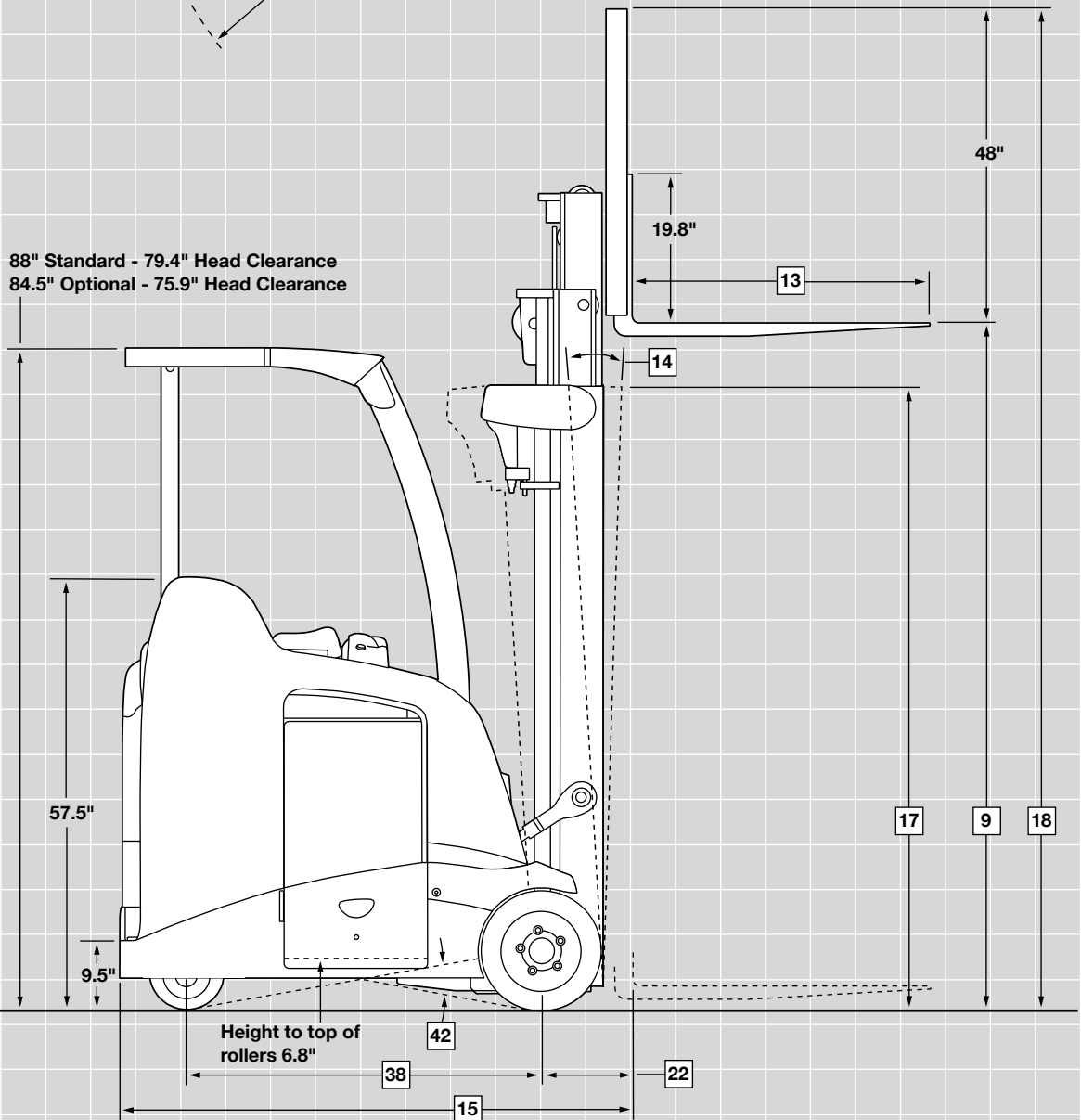
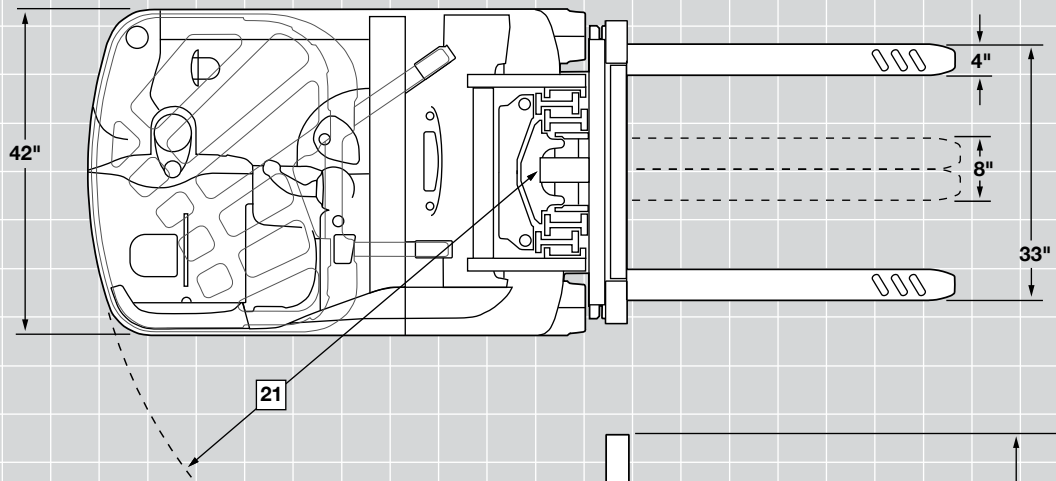

RC 5500 Series

General Information		Crown Equipment Corporation							
		Model	RC	5510/15-30	5520/25-30	5530/35-30	5530/35-35	5540/45-40	
1	Manufacturer		Crown Equipment Corporation						
2	Model	RC	5510/15-30	5520/25-30	5530/35-30	5530/35-35	5540/45-40		
3	Load Capacity*	Rated to 154 in	lb	3000	3000	3000	3500	4000	
4	Load Center	Fork Face to Load CG	in	24					
5	Power	Electric		36 Volts					
6	Operator Type			Stand-up Rider Counterbalanced					
7	Tire Type	Press-on Solid		Cushion					
8	Wheels (x = driven)	Number Front/Rear		2x / 2					
9	Mast	Lifting Height	in	See Mast Chart					
11		Free Lift Height†	in	See Mast Chart					
12	Fork Carriage			ITA Class II					
13	Forks	Standard L x W x T	in	36 x 4 x 1.5	36 x 4 x 1.5	36 x 4 x 1.5	36 x 4 x 1.75	36 x 4 x 1.75	
		Optional Lengths	in	30, 39, 42, 45, 48, 54, 60					
14	Tilt	B°/F°	degree	See Mast Chart					
15	Headlength**		in	62.9	65.2	67.5	67.7	70.1	
16	Width Overall		in	42					
17	Height	Mast Collapsed	in	See Mast Chart					
18		Mast Extended†	in	See Mast Chart					
21	Turning Radius		in	51.7	54	56.2	56.2	58.6	
22	Load Distance**	Center of Wheel to Fork Face	in	11.3			11.5		
23	Aisle Width	Right Angle Stack	in	Turn Radius + Load Distance + Load Length + Clearance					
35	Tires	Number Front/Rear		2 / 2					
36		Size Front	in	16 x 7 x 10.5					
37		Size Rear	in	10 x 5 x 6.5					
38	Wheelbase		in	42.7	45	47.2	47.2	49.6	
39	Tread Width	Front - Drive	in	35					
		Rear - Steer	in	6.7					
40	Ground Clearance, Loaded	Lowest Point	in	3.0					
41		Center of Wheelbase	in	4.2					
42	Grade Clearance, Loaded		%	41	39	37	37	35	
43	Brakes	Service		Foot - Motor					
44		Parking		Auto - Electric					
45	Battery	Type		Lead Acid					
		Compartment		B	C	D	D	E	
46		Capacity	AH	775	930	1085	1085	1240	
			KWH	27.2	32.6	38.1	38.1	43.6	
47		Weight - Min	lb	1710	1990	2280	2280	2600	
		Weight - Max	lb	1980	2270	2650	2650	3070	
		Comp't. Size - Max	Length	13.6	15.9	18.2	18.2	20.5	
			Width	38.56					
			Height	31					
48	Battery Floor Height	With Rollers	in	6.8					

* Optional masts, attachments, longer load dimensions and higher lifting heights may result in derating of the capacity. Contact your local dealer.

** Add 4.25 inches for quad masts; add 2 inches for sideshift option.

† Includes load backrest.

Performance specifications are based on a truck equipped with a 190" triple telescopic mast.

Mast Type		TT					QUAD					
9	Lifting Height	in	154	190	208	226	244	240	246	258	264	276
11	Free Lift Height	in	20.2	32.2	38.2	44.2	50.2	33.2	36.2	39.2	42.2	45.2
14	Tilt B/F*	degree	3/5	5/5	5/5	5/5	5/5	3/5	3/5	3/5	3/5	3/5
17	Mast Collapsed Height	in	71.3	83.3	89.3	95.3	101.3	83.4	86.4	89.4	92.4	95.4
18	Mast Extended Height	in	202	238	256	274	292	288	294	306	312	324

All values with 48" Load Backrest

* Forward Tilt limited to 2° above staging



Crown Equipment Corporation
New Bremen, Ohio 45869 USA
Tel 419-629-2311
Fax 419-629-3796
crown.com

You can count on Crown to build lift trucks designed for safe operation, but that's only part of the safety equation. Crown encourages safe operating practices through ongoing operator training, safety-focused supervision, maintenance and a safe working environment. Go to crown.com and view our safety section to learn more.

Because Crown is continually improving its products, specifications are subject to change without notice.

Crown, the Crown logo, the color beige, the Momentum symbol, Access 1 2 3, InfoLink, InfoPoint, e-GEN, FlexPide, Intrinsic Stability System and Work Assist are trademarks of Crown Equipment Corporation.

Copyright 2007-2009 Crown Equipment Corporation
SF18479 12/09
Printed in U.S.A.